

# The Simple Economics of Labor Standards and the GATT

by

Kyle Bagwell and Robert W. Staiger\*

Revised: May 15, 1998

## ABSTRACT

How should the issue of domestic labor standards be handled in the GATT/WTO? This question is part of a broader debate over the appropriate scope of international economic institutions such as the GATT (and now its successor, the WTO), where member-countries are considering proposals for a new round of negotiations that would move beyond GATT's existing focus on trade barriers and cover "domestic" issues such as labor and environmental standards and regulatory reform which have traditionally been treated with "benign neglect" within GATT. Such proposals encroach on traditional limits of national sovereignty, and they raise fundamental challenges to the existing structure of international economic relations among sovereign states. In this paper we consider several approaches to the treatment of domestic labor standards within a trade agreement. We use simple economic arguments to show that, while the benign neglect of labor standards within a trade agreement will result in inefficient choices for both trade barriers and labor standards, direct negotiations over labor standards are *not* required to reach efficient outcomes. Specifically, we describe two tariff negotiating structures that deliver efficient outcomes while preserving varying degrees of national sovereignty over policy choices. A first approach combines tariff negotiations with subsequent *Kemp-Wan adjustments*, under which each government is free to alter unilaterally its policy mix so long as trade volumes are not affected. A second approach adds to the first approach GATT's rule of *reciprocity*, under which subsequent to tariff negotiations each government is free to alter unilaterally its tariff, but its trading partner is then free to reciprocate with a tariff response that stabilizes export prices. We show that both approaches will deliver governments to the efficiency frontier, but that the second approach provides governments with greater sovereignty over their policy choices and bears a strong resemblance to the negotiating procedures spelled out in GATT.

JEL Nos.: F02, F13, F15.

\*Bagwell: Columbia University, Staiger: The University of Wisconsin at Madison and NBER. This paper was written for the Conference on Social Dimensions of U.S. Trade Policy, Washington, D.C., April 16-17, 1998. We thank our discussants, John Jackson and TN Srinivasan, for very helpful comments. We have also benefitted from very useful discussions with conference participants.

## I. Introduction

How should the issue of domestic labor standards be handled in the GATT/WTO? This question is part of a broader debate over the appropriate scope of international economic institutions such as the GATT (and now its successor, the WTO), where member-countries are considering proposals for a new round of negotiations that would move beyond GATT's existing focus on trade barriers and cover traditionally "domestic" issues such as labor and environmental standards and regulatory reform. Such proposals encroach on traditional limits of national sovereignty, and they raise fundamental challenges to the existing structure of international economic relations among sovereign states. In this paper we explore some of the linkages between trade policy and labor policy, and we consider several approaches to the treatment of domestic labor standards within a trade agreement.

As currently structured, GATT's approach to labor standards might be most aptly characterized as one of "benign neglect."<sup>1</sup> This characterization reflects two dimensions, the first of which is simply the degree to which GATT members are obligated to uphold a set of minimum standards for labor policies. While there is an explicit provision within GATT articles that allows governments to restrict importation of the products of prison labor, the determination of domestic labor standards is for the most part considered the legitimate domain of each national government, and weak labor standards *do not* constitute a violation of GATT obligations. Rather, as Enders (1996, p. 62) observes, "...the WTO rules place no constraints on a country's right...to regulate [its] labour practices..." This then implies a second dimension to GATT's approach to labor standards, which is essentially that the obligations on trade restrictions (e.g., tariff bindings) that a GATT member *does* accept can not lawfully and unilaterally be later modified or withdrawn in order to respond to the labor standards of a trading partner, either for the purpose of influencing the labor standards of the trading partner or to offset the cost advantages associated with those standards on

---

<sup>1</sup>See Dam (1970) and Jackson (1969, 1989) for authoritative accounts of GATT principles and practices. For a very useful discussion of the way labor standards are currently handled in the WTO, see Enders (1996).

a particular product.<sup>2</sup> Hence, for the most part, current GATT rules respect the sovereignty of domestic decisions over labor standards, as they allow each member government to determine its own labor policies without worrying about the ramifications of these choices for either its GATT obligations or those of its trading partners.

It is the wisdom of preserving this national sovereignty over domestic labor policies while at the same time negotiating successive multilateral agreements to liberalize world trade which is now being challenged from various quarters in the United States and elsewhere in the industrialized world. The primary concern voiced by labor interests and social activists is that working conditions and wages in industrialized countries will suffer from trade liberalization as a result of increased import competition from countries where labor standards are weak or not enforced. It is feared that such pressures could fuel a “race to the bottom,” in which the labor standards of the industrialized world are compromised in the name of international “competitiveness.” These concerns have in turn led to proposals to introduce the issue of labor standards directly onto the negotiating agenda of the WTO, with the purpose of creating a “social clause” for the WTO that would permit restrictions to be placed on imports from countries not complying with a specified list of minimum standards (see, for example, the description of these proposals in Maskus, 1997, pp. 58-62). These proposed changes would allow governments to raise import restrictions in response to the weak labor standards of their trading partners, and if adopted these changes would mark a dramatic departure from the “benign neglect” approach to labor standards that has been followed by GATT over its 50 year history. With the WTO facing proposals for such fundamental changes in its approach to the issue of domestic labor

---

<sup>2</sup>This is not to say that GATT members have *no* ability to respond to the labor standard choices of their trading partners. As Enders (1996, pp. 64-65) observes, if the tariff in question is not bound in a GATT schedule, then a country is of course free to raise the tariff for this (or any other) reason, and even where the tariff in question is covered by a GATT binding the country could still raise the tariff through an Article XXVIII modification, though it would then be obligated to make “compensatory adjustments” under which it lowered other tariffs or else face a “reciprocal” tariff increase from its trading partner. Moreover, in principle, a claim of “nullification and impairment” associated with a trading partner’s labor policies might successfully be brought under GATT’s dispute settlement procedures if it could be shown that these labor policies interfered with market access in a way that could not reasonably have been anticipated at the time of the tariff negotiations. In practice, however, the burden of proof and other features of so-called “non-violation” complaints under GATT’s dispute settlement procedures make them difficult to carry out, and from 1947 through 1995 only 14 out of the more than 250 GATT dispute proceedings centered on such complaints (see, for example, Petersmann, 1997, pp. 135-176).

standards, it is a good time to consider the question: How *should* the issue of domestic labor standards be handled in the GATT/WTO?

Much has been written on the interaction between international trade and labor standards (see, for example, Brown, Deardorff and Stern, 1996, Srinivasan, 1996, and the papers dealing with this issue from a legal perspective in the authoritative volumes edited by Bhagwati and Hudec, 1996, as well as the very useful discussion of the issues and literature contained in Brown, Deardorff and Stern, 1997), and no single paper can do justice to the broad set of issues that are involved. However, an important dimension that is absent from this literature is a formal economic analysis of the interaction between negotiations over trade policy and the determination of labor standards.<sup>3</sup> Yet it is within the context of sustained negotiations to liberalize world trade that the need to negotiate international agreements over labor standards has been most forcefully raised, and it is from the backdrop of GATT's successes in securing low levels of negotiated tariffs on a multilateral basis that the case for adding labor standards to the negotiating agenda of the WTO must be evaluated. Hence, an understanding of the interaction between tariff negotiations and the determination of labor policies seems a necessary starting point for assessing the claim that labor standards will suffer as a result of trade liberalization and for considering how the issue of labor standards ought to be approached by the WTO.

In this paper we evaluate the relative merits of several approaches to the treatment of domestic labor standards within a trade agreement, ranging from one extreme that reflects GATT's current approach of benign neglect all the way to the other extreme of direct negotiations over labor standards to create a social clause for the WTO. Our broader intent in this research is to provide an answer to the question we posed at the outset of this paper. Here we narrow our focus to a more modest goal: we present a simple economic model within which some of the central features of the interaction between trade policy and labor standards may be understood, and we use this analytical

---

<sup>3</sup>For example, Brown, Deardorff and Stern (1996) focus on the welfare and terms-of-trade effects of the imposition of labor standards in the presence of free trade but do not consider the choice of tariff policy, while Srinivasan (1996) considers whether diversity of labor standards alters the case for free trade but is not concerned with whether trade liberalization might alter a country's choice of labor standards.

structure to draw attention to an observation that has to our knowledge not appeared previously in the literature and that seems to us to be worthy of further discussion. In particular, we show that, while the benign neglect of labor standards within a trade agreement will result in inefficient choices of both trade barriers and labor standards, direct negotiations over labor standards are *not* required to reach efficient outcomes. Rather, as we demonstrate below, more modest changes to existing GATT rules could in principle correct the problems associated with GATT's current approach to labor standards without the need to engage in direct negotiations over these domestic policies.

The basic insight that underlies our findings is quite simple, and can be seen intuitively by considering the following situation. Imagine two college students who live in separate dorm-rooms across a shared courtyard. Both own stereos but each has a distinct taste in music, and each likes to listen to his own music both in his room and when walking in the courtyard. The courtyard is sufficiently large that neither student's stereo can be heard inside the other student's room, but both stereos can potentially be heard in the courtyard. All else equal, each student would prefer that his music dominate that of his neighbor over as much of the courtyard as possible. The louder is one of the stereos turned up relative to the other, the further out into the courtyard it will dominate the other. Hence, each student is aware that by turning up his stereo he can restrict the audible range of his neighbor's music in the courtyard as he simultaneously extends the audible range of his own.

In this setting, consider what problems will arise when the two students set their stereo levels non-cooperatively, and consider as well what kinds of cooperative agreements might be entertained. Without some kind of cooperation, both students will turn up their stereos in a competition to dominate the courtyard, and each student will therefore play his stereo at a level which is louder *inside* his room than he would choose in the absence of the courtyard competition. An obvious solution to this inefficient situation is for the two students to agree to turn down their stereos to mutually acceptable levels, perhaps preserving the relative balance in the courtyard but achieving desired reductions in the sound level inside each room. However, an agreement that simply specified the setting of the volume knob for each stereo would now tempt each student to achieve dominance in the courtyard by less direct means, perhaps for example by reorienting his speakers increasingly

in the direction of the courtyard window. Of course, the distortions to in-room listening associated with manipulating speaker locations would create new inefficiencies, and these new inefficiencies could also be handled in the same way as the volume settings, by broadening the agreement to cover both the setting of the volume knob and the placement of the speakers in each room. And in principle this broadening could go on until the negotiations covered every conceivable angle that either student might test in his effort to achieve dominance in the courtyard.

But an alternative approach to negotiations is also possible once the essential features of the problem are understood. Since each student is driven to make inefficient choices regarding his stereo operation by the incentive to affect the *courtyard volume* of his music relative to that of his neighbor, each student could in principle retain the right to unilaterally determine the details of his stereo operation without sacrificing efficiency provided that he faced appropriate restrictions under the agreement that offset this incentive. For instance, an agreement could simply specify courtyard volume levels for each stereo directly, and then let each student decide on how best to satisfy the terms of the agreement (e.g., what combination of volume-knob setting and speaker placement consistent with the agreed-upon courtyard volume would provide him with the best in-room listening).

As it turns out, the analogy between the situation described above and that faced by trade negotiators is surprisingly close in its essentials. In the absence of any form of international (inter-room) agreement, governments (students) will tend to raise tariffs (volume knob settings) to inefficiently high levels in an effort to restrict the market access of foreign products (drown-out competing stereos) and enjoy the lower foreign exporter prices (reduced audible range of competing music) that result. This is the fundamental inefficiency that a trade agreement such as GATT can correct.<sup>4</sup> However, if an agreement is negotiated that covers only direct restrictions on trade such as tariffs, the unilateral urge to limit market access will be deflected on to “domestic” policies such

---

<sup>4</sup>In Bagwell and Staiger (1996, 1997, forthcoming) we establish that this is the essential inefficiency that underlies the possible gains from a trade agreement in a broad class of settings that include both economic and political motives for member-governments.

as labor standards, whose determination will then be distorted as a consequence of negotiated trade liberalization. While introducing labor standards directly onto the negotiating agenda could in principle eliminate these new distortions, it is not necessary to do so: once the source of the unilateral incentive to distort labor standards is understood to be derived from the incentive to limit market access, governments can retain the right to unilaterally determine their own labor standards without sacrificing efficiency provided that they face appropriate restrictions on their choices which offset these incentives. As we establish below, the restrictions that work in principle are closely related to those embodied in current GATT practice, suggesting that more modest changes to existing GATT rules might provide an alternative to the direct negotiation of a social clause.

Throughout the paper we attempt to keep technical material to a minimum, so that the ideas may be highlighted as clearly as possible. We rely primarily on a series of graphs to express our results. A more general mathematical treatment of these and other issues relating to standards and trade policy may be found in Bagwell and Staiger (1998). But it is nevertheless important to bear in mind that our formal analysis abstracts from many of the difficult issues associated with the determination of national labor standards in an international setting. For this reason, we do not interpret our results as implying that bringing labor standards into the WTO is a good idea. To come to such a view, many other complications that we have ignored would have to be considered. Rather, we interpret our results as implying that, *if* the WTO is going to act to address this issue of labor standards, then there are more modest changes to existing GATT rules that ought to be considered as an alternative to a WTO social clause.

The rest of the paper proceeds as follows. The next section presents the benchmark case of the choice of labor standards in a closed economy. In section III we then open this economy to trade and consider how import-competition alters the determination of its labor standards. In section IV we introduce tariffs as a second policy variable, so that we may consider how trade policy and labor standards can interact. Here we establish that international negotiations over tariffs alone will lead to a globally inefficient outcome described by partial tariff liberalization and a weakening of labor standards. In section V we take up the issue of how GATT negotiations can be structured to

strengthen labor standards and achieve efficient outcomes. Finally, section VI concludes.

## II. Labor Standards in a Closed Economy

In this section we present the benchmark case of the choice of labor standards in a closed economy. We choose our set of modeling assumptions to reflect some basic features of the issues described above that we wish to capture. Whenever there is a choice between generality and clarity we opt for the latter. Hence, rather than making a claim on generality, our model should be seen as simply serving to illustrate some basic points that should be kept in mind in the broader debate over the appropriate handling of labor standards within GATT. As we will be particularly interested in examining how import competition affects the choice of labor standards, we will consider an “industrialized” economy that determines its labor standard in an industry that may face import competition from a “less-industrialized” economy abroad. We first consider the issues involved in determining the labor standard for this industry when it does not face import competition (i.e. in a closed economy), and then in the next section turn to a trading environment.

We focus on a single good  $x$  which, with  $p_x$  denoting its price, will be consumed by this economy at the rate  $C_x(p_x)=1-p_x$  and produced at the rate  $Q_x(p_x,s)=(1-s)+p_x$ . The parameter  $s$  lies between zero and one and denotes the economy’s *labor standard*, with  $s=0$  corresponding to a “loose” labor standard and  $s=1$  corresponding to a “tight” labor standard. Consider, for example, the possibility that  $s$  denotes the stringency of child labor laws. If children of any age could be legally employed in the production of  $x$  in this economy, then we would represent this by setting  $s=0$ , and the economy’s supply of  $x$  would be given by  $Q_x=1+p_x$ . At the other extreme, if children were strictly prohibited from working in the  $x$  industry, then we would represent this by setting  $s=1$ , and the economy’s supply of  $x$  would then be “shifted in” and given by  $Q_x=p_x$ . More generally, the labor standard may be set at some intermediate level, in which case the parameter  $s$  would be greater than zero but less than one, and the economy’s supply of  $x$  would lie somewhere in between the two extremes just described.

The top panel of Figure 1 illustrates the market for  $x$  in this closed economy, with  $x$ -demand given by the downward-sloping line, and with  $x$ -supply given by the upward sloping line intersecting the  $x$ -axis at the value  $(1-s)$ . The “autarky” (closed economy) equilibrium price of good  $x$  will equate the country’s supply and demand, and is labeled in the top panel of Figure 1 by  $p_x^A$ . Notice that a more stringent labor standard (a higher  $s$ ) will result in a leftward shift of supply and therefore an increase in  $p_x^A$ . This simply reflects the fact that more stringent labor standards will reduce the supply of workers available to the industry, and the market-clearing price will rise as a consequence.

Our partial equilibrium focus allows economic surplus associated with industry  $x$  in this closed economy to be measured as the sum of consumer surplus and producer surplus. In the equilibrium depicted in the top panel of Figure 1, consumer surplus is given by the area under the demand curve and above the market-clearing price  $p_x^A$ , while producer surplus is given by the area above the supply curve (and the  $x$ -axis) and below  $p_x^A$ .

It can be seen by inspection of the top panel of Figure 1 that the economic surplus in industry  $x$  will be smallest when  $s=1$ , so that the labor standard is at its most stringent: when  $s=1$  the supply curve intersects the  $x$ -axis at the origin, and so the market-clearing price is one-half and the economic surplus is one-quarter, as measured by the sum of the areas of the consumer and producer surplus triangles, each with height one-half and base one-half. On the other hand, economic surplus in industry  $x$  achieves its maximum value when  $s=0$ , so that the labor standard is at its most lax: when  $s=0$  the supply curve intersects the  $x$ -axis at one, and so the market-clearing price is zero and the economic surplus is one-half, as measured by the area of the consumer surplus triangle, with height one and base one.<sup>5</sup> These observations reflect our implicit assumption that workers excluded from industry  $x$  as a result of tightening labor standards (a rise in  $s$ ) can not work elsewhere in the economy, and therefore contribute nothing to economic surplus in an alternative use. Hence, from the point of view of economic surplus, labor standards in this simple setting have only economic costs and no economic benefits.

---

<sup>5</sup>In fact, the economic surplus associated with industry  $x$  in a closed-economy setting takes the very simple algebraic form of  $(2-s^2)/4$ .

Of course, even if it is costly from an economic standpoint, a society may still decide to exclude certain segments of the population (e.g., children) from the workforce for “non-economic” social reasons, and we assume that the government of this economy does place value on more stringent labor standards for social reasons. In particular, we assume that the government values increases in  $s$  at the rate  $\lambda$ .<sup>6</sup> Hence, in determining the stringency of the labor standard to apply to industry  $x$ , the government faces a tradeoff between lower economic surplus (as measured in the top panel of Figure 1) and greater social surplus (as measured by its valuation parameter  $\lambda$ ).

In the bottom panel of Figure 1, we depict this tradeoff by displaying separately the levels of economic and social surplus achieved in this closed economy as a function of the choice of labor standard  $s$ . The level of economic surplus is given by the dashed curve in the bottom panel of Figure 1. This curve plots as a function of  $s$  the economic surplus determined in the top panel of Figure 1, and it is decreasing monotonically as  $s$  increases from zero to one. The level of social surplus is given in the bottom panel of Figure 1 by the straight line out of the origin with slope  $\lambda$ . The sum of economic and social surplus in this closed economy for any choice of  $s$ , which we denote by  $W_x^A(s)$ , is then depicted by the bold curve in the bottom panel of Figure 1.<sup>7</sup> Henceforth we will refer to  $W_x^A(s)$  as the *domestic surplus* associated with a given labor standard  $s$ .

We assume that the government chooses its labor standard  $s$  in autarky to maximize domestic surplus  $W_x^A(s)$ , and therefore it chooses the value of  $s$  associated with the highest point on the bold curve in the bottom panel of Figure 1. It is straightforward to show that setting the labor standard at a value of  $2\lambda$  achieves this maximum, and so the government’s chosen labor standard in autarky will be given by  $s^A \equiv 2\lambda$ . This solution reflects an optimal balance between the attainment of social goals and the economic costs of achieving those goals in a closed economy.

---

<sup>6</sup>The parameter  $\lambda$  is taken to be a positive constant. Provided that  $\lambda < 1/4$ , the chosen labor standard will lie strictly between zero and one.

<sup>7</sup>More specifically, we have  $W_x^A(s) = (2-s^2)/4 + \lambda s$ .

### III. How Import-Competition Alters the Determination of Labor Standards

Suppose now that the domestic country has an opportunity to trade with a foreign country, and suppose that the forces of comparative advantage would dictate that the foreign country export good  $x$  to the domestic market. In the face of import-competition, how will the domestic government's choice of labor standards be altered? This is the question we now seek to answer.

We consider first how the advent of trade alters the economic surplus associated with industry  $x$  when the domestic labor standard is fixed at the level chosen in autarky,  $s^A$ . We suppose that foreigners consume good  $x$  at the rate of  $C_x^*(p_x^*)=1-p_x^*$ , where  $p_x^*$  denotes the price of good  $x$  in the foreign country. For simplicity, we abstract from the issue of foreign labor standards, and assume simply that foreign supply of good  $x$  is given by  $Q_x^*(p_x^*)=1+p_x^*$ .<sup>8</sup>

The top panel of Figure 2 depicts the free trade equilibrium between the domestic and foreign country when the domestic labor standard is fixed at  $s^A$ . The figure on the left depicts the demands and supplies of the home country as a function of the prevailing home-country price of good  $x$ . The figure on the right depicts the demands and supplies in the foreign market as a function of the price of good  $x$  prevailing there. Free trade will ensure that a single price of  $x$  prevails in the two markets, so that  $p_x=p_x^*$ , and this common price will be determined in equilibrium so that the difference between demand and supply of good  $x$  in the home country (the *domestic import demand*,  $M_x(p_x, s^A) \equiv C_x(p_x) - Q_x(p_x, s^A)$ ) is equal to the difference between supply and demand of good  $x$  in the foreign country (the *foreign export supply*,  $E_x^*(p_x^*) \equiv Q_x^*(p_x^*) - C_x^*(p_x^*)$ ). The equilibrium free trade price is labeled  $p_x^F$  in the top panel of Figure 2, and this price will prevail in each market (i.e.,  $p_x=p_x^F=p_x^*$ ).

---

<sup>8</sup>It might be objected at this point that we are “throwing the baby out with the bath water.” After all, it is the allegation of weak labor standards in less-industrialized countries that gives rise to the fear that free trade with these countries will weaken the labor standards of industrialized countries as well. However, notice that the *channel* through which such pressures must be exerted is trade, regardless of the reasons for that trade. Our approach here is therefore to abstract from the reasons for trade (which could include weak labor standards in the exporting country) and focus on the implications of that trade for labor standards in the import-competing country.

Notice that at the free trade equilibrium price  $p_x^F$  depicted in the top panel of Figure 2, the domestic country enjoys increased economic surplus associated with industry x relative to the economic surplus associated with this industry in autarky (i.e., at  $p_x^A$ , where the domestic demand and supply curves intersect). The increase in surplus for the domestic country amounts to the area above  $p_x^F$  and below both the domestic demand and supply curves, and in the top panel of Figure 2 we label this additional surplus  $G_x^F(s^A)$ . Given the labor standard  $s^A$ ,  $G_x^F(s^A)$  simply measures the additional economic surplus that the domestic country achieves through free trade with its foreign trading partner, or the domestic country's *gains from trade*. Likewise, the gains from trade for the foreign country are given in the top panel of Figure 2 by the area below  $p_x^F$  and above both the foreign demand and supply curves, and we label this area  $G_x^{F*}(s^A)$ .

The gains from trade for the domestic country can be measured equivalently as the area above the equilibrium price and below the domestic country's import demand curve  $M_x(p_x, s^A)$ . Analogously, the gains from trade for the foreign country can be measured equivalently as the area below the equilibrium price and above the foreign country's export supply curve  $E_x^*(p_x^*)$ . In the bottom panel of Figure 2, the domestic import demand and foreign export supply curves are depicted, with the equilibrium free trade price and trade volume determined by their intersection (with the latter labeled  $M_x^F$ ) and the domestic and foreign gains from trade labeled as  $G_x^F(s^A)$  and  $G_x^{F*}(s^A)$ , respectively. The top and bottom panels of Figure 2 are simply equivalent ways of depicting free trade equilibrium and the gains from trade.

Notice in the bottom panel of Figure 2 that the domestic import demand curve intersects the x-axis at a value equal to the choice of domestic labor standard, and that the gains from trade are therefore affected by the choice of domestic labor standard. In particular, as can be seen from inspection of the bottom panel of Figure 2, each country's gains from trade would be larger if the domestic government would tighten its labor standard beyond  $s^A$ , as this would shift out the domestic import demand curve and thereby increase the size of each of the gains-from-trade triangles

beyond those depicted in the figure.<sup>9</sup> The linkage between domestic labor standards and the gains from trade simply reflects the fact that, as the domestic labor standard is tightened, the two countries become increasingly “different,” and they are able to exploit these differences as the basis for trade. This suggests that, when faced with the prospect of international trade, the domestic government may wish to take account of the impact of its labor standard on the gains from trade as it determines its preferred level for this standard.

To highlight the impact that international trade has on the domestic government’s choice of labor standard, we therefore decompose the economic and social surplus it achieves with any choice of  $s$  under free trade, which we denote by  $W_x^F(s)$ , into the sum of (i) the domestic surplus its labor standard choice would generate in autarky,  $W_x^A(s)$ , and (ii) the domestic gains from trade associated with this choice,  $G_x^F(s)$ . That is, we write the level of free-trade economic and social surplus achieved by the domestic government under any labor standard  $s$  as  $W_x^F(s) \equiv W_x^A(s) + G_x^F(s)$ .

This decomposition is depicted in Figure 3, the top panel of which depicts the economic and social surplus associated with free trade when the domestic labor standard is set at the level determined in autarky,  $s^A$ . The domestic surplus,  $W_x^A(s)$ , is plotted (in an inverted fashion) below the x-axis as a function of  $s$ . As was shown in Figure 1,  $W_x^A(s)$  reaches its maximum when  $s = s^A$ , and this is reflected as well in the top panel of Figure 3, where it can be seen that a small movement in  $s$  away from  $s^A$  would leave the value of  $W_x^A(s)$  unaltered at its (maximal) value of  $W_x^A(s^A)$ . Above the x-axis domestic import demand and foreign export supply are plotted. As observed previously, the domestic import demand curve intersects the x-axis at a value equal to the domestic labor standard  $s$ , and with the domestic labor standard set at the level determined in autarky this intercept occurs at  $s^A$  as depicted. The associated domestic gains from trade are labeled  $G_x^F(s^A)$ . Therefore, the surplus achieved by the domestic government under the labor standard  $s^A$  in the presence of free international trade is given by  $W_x^F(s^A) = W_x^A(s^A) + G_x^F(s^A)$ , with the determination of  $W_x^A(s^A)$  and  $G_x^F(s^A)$  each reflected in the top panel of Figure 3.

---

<sup>9</sup>Specifically, for  $s$  between zero and one, we have  $G_x^F(s) = G_x^{F*}(s) = (s/4)^2$ .

An important implication of international trade for the choice of labor standards can now be seen. As reflected in the top panel of Figure 3, *when faced with import competition from abroad, the domestic government can always improve upon  $s^A$  with a small strengthening of its labor standard* (a slightly higher  $s$ ). This is because a slight strengthening of domestic labor standards from  $s^A$  will have no impact on domestic surplus  $W_x^A(s)$ , but it will increase the domestic gains from trade  $G_x^F(s)$ . In effect, while  $s^A$  reflects the optimal balance between the social benefits of more stringent labor standards and the economic costs of achieving them in a closed economy (i.e.,  $s^A$  maximizes  $W_x^A(s)$ ), the opportunity to import from abroad reduces the domestic country's economic costs of achieving more stringent labor standards, and makes the choice of tighter labor standards ( $s > s^A$ ) desirable for the domestic government as a result.

The bottom panel of Figure 3 depicts the end result of this process, where the domestic government has set its labor standard at a level that balances the domestic social benefits of tight labor standards against the domestic economic costs of achieving these goals in an open economy. As depicted, the optimal labor standard level is higher than  $s^A$  and given by  $s = 8\lambda/3 \equiv s^F$ , and at this standard level the additional gains from trade for the domestic country that would be generated by a further tightening of domestic labor standards (the increase in  $G_x^F(s)$  associated with a small increase in  $s$  above  $s^F$ ) would just be matched by the reduction in domestic surplus ( $W_x^A(s)$ ) that the change in labor standards would generate.

Hence we have:

**Observation 1:** Import competition is not an “enemy” of strict labor standards. Countries will adopt more stringent labor standards in the presence of import competition than they would choose to adopt in its absence.

While we have focused on the impact of import competition on labor standards, similar

arguments can be used to show that just the opposite forces are at work in export sectors.<sup>10</sup> Hence, more generally trade will induce governments to *reorient* their labor standards toward greater stringency in import-competing industries and greater laxity in export sectors. But the essential point remains, namely, that there is nothing about exposure to international trade per se that leads inexorably to weaker labor standards.

#### **IV. How Trade Liberalization can Weaken Labor Standards**

Thus far we have concerned ourselves with the way that trade and labor standards can interact, assuming that trade remains free of impediments when it occurs. We now introduce the possibility that import tariffs may be imposed, and consider how trade *policy* and labor standards can interact. To do this, we proceed in three steps. Our first step is to determine the import tariff and labor standard choices that would be optimal for the domestic government in the absence of any possibility of international policy cooperation with its foreign trading partner. Our second step is to identify inefficiencies associated with these unilateral policy choices, so that the possibility of creating mutual increases in welfare (by eliminating these inefficiencies) can be established and the basis for a cooperative international agreement over trade and labor policies may be understood. Our third and final step in this section is then to consider whether all the potential benefits from international cooperation can be achieved with an agreement over trade policy alone.

As we showed in the previous section, the opportunity to import from abroad reduces the domestic country's economic costs of achieving more stringent labor standards, and makes the choice of tighter labor standards desirable for the domestic government as a result. When the domestic government also has an import tariff at its disposal, it has an enhanced ability to "shift the costs" of its more stringent labor standards onto its trading partner through import protection, and this leads it to favor more stringent labor standards than it would choose under free trade. Hence, as we now

---

<sup>10</sup>A formal confirmation of this can be found in the model detailed in the Appendix to the Comment by our discussant, TN Srinivasan.

show, *the ability to impose import protection goes hand-in-hand with tighter labor standards.*

To see this, consider the domestic country's gains from trade in industry x when its labor standard is set at the level which would be chosen under free trade,  $s^F$ , but when it sets an ad valorem import tariff  $t$  on imports of x from the foreign country. Letting  $\tau \equiv (1+t)$ , the domestic country's tariff will drive a wedge between the domestic and foreign price of x, and provided the tariff is not set so high as to prohibit imports altogether, the resulting trade volume will ensure that  $p_x = \tau p_x^*$ . This tariff wedge will alter the gains from trade achieved by each country under the domestic labor standard  $s^F$  from the gains each would have received under free trade, and this in turn will upset the tradeoff between domestic surplus and the gains from trade which, under free trade, led the domestic government to choose the labor standard  $s^F$ . Consequently, import protection will render  $s^F$  sub-optimal, and a link between import protection and labor standards can be established.

Figure 4 illustrates. The top panel depicts the domestic surplus ( $W_x^A(s^F)$ ) and the domestic gains from trade ( $G_x^T(s^F, \tau)$ ) associated with the domestic labor standard  $s^F$  and a (non-prohibitive) domestic import tariff  $\tau$ .<sup>11</sup> Domestic surplus is plotted below the x-axis as a function of the domestic labor standard  $s$  and, as depicted, the labor standard level  $s^F$  is determined so as to balance the reduction in domestic surplus that a further tightening of the standard would generate against the additional domestic gains from free trade that would be created. With the introduction of a domestic import tariff  $\tau$ , the domestic government increases the price of x prevailing in its own market while it decreases the price of x prevailing in the foreign market relative to the (common) free trade price  $p_x^F$ , and in so doing it reduces import volume below the free trade level  $M_x^F$ . In the top panel of Figure 4, the equilibrium domestic and foreign prices associated with the domestic import tariff  $\tau$  are labeled as  $p_x^T$  and  $p_x^{T*}$ , respectively, while the equilibrium import volume is labeled  $M_x^T$ . The domestic gains from trade  $G_x^T(s^F, \tau)$  are now given by the area above  $p_x^T$  and below the domestic

---

<sup>11</sup>In the presence of a domestic import tariff  $\tau$ , the domestic gains from trade function can be written algebraically for any labor standard  $s$  as  $G_x^T(s, \tau) = [(2\tau - 1)s^2] / [4(1 + \tau)^2]$ , while the foreign gains from trade function is given by  $G_x^{T*}(s, \tau) = s^2 / [4(1 + \tau)^2]$ .

country's import demand curve *plus* the area above  $p_x^{T*}$  and below  $p_x^T$  out to  $M_x^T$  (which is the tariff revenue collected by the domestic government). The foreign country's gains from trade  $G_x^{T*}(s^F, \tau)$  are given by the area below  $p_x^{T*}$  and above the foreign export supply curve. The area of the triangle labeled  $D$  corresponds to the *dead weight loss* associated with the import tariff  $\tau$ , as this amount of free trade surplus is lost in the presence of the tariff.

It can now be seen from the top panel of Figure 4 that the additional domestic gains from trade generated by a slight tightening of the domestic labor standard beyond  $s^F$  will be higher when the domestic government can impose an import tariff than when it is restricted to a policy of free trade.<sup>12</sup> To see this, consider a small increase in  $s$  starting from  $s^F$ , and suppose that the domestic government were to adjust the level of its import tariff  $\tau$  to keep the dead weight loss associated with its tariff policy ( $D$  in the figure) unchanged. Such a tariff adjustment would certainly be feasible for the domestic government (and if it is not optimal then the domestic government could only increase its gains from trade further by adjusting its tariff to the optimal level). With this tariff adjustment holding  $D$  fixed, the increase in the *total* (i.e., domestic plus foreign) gains from trade generated by the rise in  $s$  will be the same as the increase in the total gains from *free* trade when  $s$  rises. But the domestic country's *share* of this increase will be larger than it would be under free trade, owing to the low foreign price  $p_x^{T*}$  received by foreign exporters (and the tariff revenue collected from foreign exporters by the domestic government as a consequence). Therefore, with an import tariff at its disposal, the domestic government can generate larger increases in its gains from trade as it strengthens its labor standard than it would enjoy under free trade. This implies in turn that import protection will render  $s^F$  sub-optimal, and that the domestic government will wish to strengthen its labor standard when it can also impose import protection.

The bottom panel of Figure 4 depicts the domestic government's choice of labor standard and import tariff. For any choice of labor standard, the import tariff will be set to maximize the domestic gains from trade, and it is straightforward to show that setting  $\tau = 2 \equiv \tau^N$  achieves this goal. The

---

<sup>12</sup>Formally, for  $\tau \in (1, \tau^N]$  we have  $\partial G_x^T(s, \tau) / \partial s = [s(2\tau - 1)] / [2(1 + \tau)^2] > s/8 = \partial G_x^F(s) / \partial s$ .

domestic labor standard is then set where a further tightening would generate losses in domestic surplus ( $W_x^A(s)$ ) which are just matched by the added domestic gains from trade ( $G_x^T(s, \tau^N)$ ). This point is reached by strengthening the domestic labor standard beyond  $s^F$  to  $s=3\lambda \equiv s^N$ , at which point the domestic government has set its labor standard at a level that balances the domestic social benefits of tight labor standards against the domestic economic costs of achieving these goals in an open (but protected) economy.

Having established that the ability to impose import protection leads the domestic government to choose tighter labor standards, we now proceed to our second step and characterize the labor standard and trade policy choices that would be *efficient* from a world-wide perspective. We assume that the two countries have a means of redistributing income between them in a lump sum fashion, as this allows us to focus on the policy choices that would maximize their joint surplus. As is well-understood, efficiency can not be achieved in this environment in the presence of import tariffs, and so efficiency will require that the domestic import tariff be set to zero ( $\tau=1$ ) so that free trade can prevail. The remaining question concerns the efficient choice of domestic labor standard  $s$ . We now show that a further strengthening of domestic labor standards is required for efficiency.

Figure 5 demonstrates why this must be so. The top panel of Figure 5 recreates the determinants of the domestic government's choice of labor standards under free trade,  $s^F$ . Recall that this choice balances the reduction in domestic surplus that a further tightening of labor standards would cause against the generation of additional domestic gains from trade  $G_x^F(s)$ . But to achieve an efficient labor standard, the impact of this standard on *foreign* gains from trade  $G_x^{F*}(s)$  must be taken into account as well, and foreign gains from trade also increase with a strengthening of domestic labor standards. Hence, domestic labor standards impart a positive externality on foreign welfare, and efficiency requires that this externality be internalized with more stringent domestic labor standards than would be chosen by the domestic government on its own. The bottom panel of Figure 5 depicts the determination of the efficient domestic labor standard. When this standard is increased to  $s=4\lambda \equiv s^E$ , a further rise in  $s$  would lead to a reduction in domestic surplus which is just offset by the increase in domestic and foreign gains from trade. As depicted in the figure, the efficient labor

standard ( $s^E$ ) is more stringent than that which the domestic government would choose in the absence of any international cooperation ( $s^N$ ), and so *an international agreement that achieves efficiency must call for free trade and tighter labor standards.*

This brings us to the third and final step in considering how trade policy and labor standards can interact. We now wish to determine whether all the potential benefits from international cooperation can be achieved with an agreement on trade policy alone. That is, we suppose initially that tariff and labor policies are set non-cooperatively and that then the domestic and foreign governments are given the opportunity to negotiate a tariff agreement, but that domestic labor policy will continue to be set unilaterally by the domestic government. As before, with international lump sum transfers available, the two governments will negotiate a tariff agreement that maximizes their joint surplus, but they must now take into account the fact that domestic labor policy will be set unilaterally by the domestic government in light of their tariff agreement. The question we now consider is whether the inability to negotiate an agreement on labor standards will alter the content of the tariff agreement or the surplus achieved through negotiation. As we now establish, *international negotiations over tariffs alone will lead to a globally inefficient outcome described by partial tariff liberalization and a weakening of labor standards.*

Figure 6 illustrates the result. The top panel represents the determination of non-cooperative trade and labor policies  $\tau^N$  and  $s^N$ . As established previously, these policies are inefficient, as full efficiency requires that the domestic country's import protection be eliminated and that its labor standard be strengthened to  $s^E$ . The domestic government could simply agree to eliminate its tariff, thereby securing one part of the efficient policy combination. However, as domestic labor policy is "off limits" to negotiation by assumption, an agreement which achieved free trade would induce the domestic government to *weaken* its labor standard below  $s^N$  to  $s^F$ . But efficiency calls for a *strengthening* of domestic labor standards beyond  $s^N$  to  $s^E$ . Hence, as the domestic government agrees to liberalize its trade policy, it will unilaterally be adjusting its labor standard in the wrong direction from the standpoint of world-wide efficiency and creating further distortions. As a consequence, it will not be efficient to negotiate a tariff agreement that calls for free trade. Instead,

(constrained) efficiency will call for a balance between the costs of distortions in trade policy and the costs of distortions in labor standards.

The bottom panel of Figure 6 shows the determination of the optimal tariff agreement when labor standards are beyond the reach of international negotiations. The agreement calls for tariff liberalization to achieve a tariff below the non-cooperative tariff  $\tau^N$ , but this liberalization does not go all the way to free trade. Rather, the tariff level  $\tau^G$  called for in the agreement lies strictly between free trade and the non-cooperative tariff  $\tau^N$ . At the optimal negotiated tariff  $\tau^G$ , a slight amount of additional tariff liberalization would create additional domestic and foreign gains from trade (through a further reduction in the dead weight loss  $D$ ) which would be just offset by the reductions in domestic and foreign gains from trade and the increases in domestic surplus that come with the weaker domestic labor standards that further tariff liberalization would engender. As indicated in the figure, the agreed-upon tariff liberalization to  $\tau^G$  will induce the domestic government to choose (unilaterally) to weaken its labor standard from  $s^N$  to  $s^G$ . Hence, the optimal tariff agreement will fail to eliminate tariffs as it leads to weaker labor standards, and consequently the surplus generated by an agreement over tariffs alone can not achieve the level of surplus attainable with international cooperation over both trade and labor policies.

Thus we have:

**Observation 2:** International negotiations over tariffs alone will lead to a globally inefficient outcome described by partial tariff liberalization and a weakening of labor standards in import-competing industries.

Again we note that this observation reflects our focus on the interaction between labor standards and import competition, and opposite forces will be at work with regard to the choice of labor standards whose central effects are on export sectors. However, this focus does give some credence to the view that successive rounds of GATT-sponsored tariff liberalization may be fueling a “race to the bottom” in which the labor standards of the industrialized world are being sacrificed

in the name of international “competitiveness.”<sup>13</sup> It is from such a backdrop that proposals to introduce the issue of labor standards onto the WTO agenda are often advanced. In the next section we consider a number of approaches that might be taken to handle the issue of labor standards within the WTO.

## V. How GATT Negotiations can be Structured to Strengthen Labor Standards

In the preceding section we showed that tariffs and labor-standards will be set at inefficient levels if they are determined non-cooperatively, and that attempts to address these problems through international negotiations over tariffs alone will lead to globally inefficient outcomes characterized by partial tariff liberalization and a weakening of labor standards. In this section we consider three approaches to negotiations that can achieve efficient outcomes. We begin with the most obvious approach, which is to introduce the issue of labor standards directly on to the agenda of international trade negotiations.

It is clear that direct negotiations over tariffs and labor standards together will allow the domestic and foreign government to negotiate to the efficient outcome of free trade and a domestic labor standard  $s^E$  (with a possible need for lump sum international payments across countries). However, it is interesting to note that the addition of labor standards to the negotiating agenda will not only result in an agreement to strengthen labor standards, but will make further tariff liberalization desirable as well. To see this, we refer to Figure 7, the top panel of which depicts the determination of the optimal tariff agreement when negotiations over labor standards is not allowed. As described

---

<sup>13</sup>In practice there may also be an important “North-South” asymmetry at work that serves to diminish the extent of interaction between tariff liberalization and the choice of labor standards in export industries, and which thereby serves to further justify our focus on labor standards in an import-competing industry. In particular, if we think of the group of less-industrialized countries who export labor-intensive goods to their large industrialized trading partners as individually being unable to have significant impacts on export prices in the world economy, then the incentive to distort labor standards in import-competing industries as we have analyzed it above will exist for the industrialized countries, but there will be no analogous incentive to distort labor standards in the export sectors of the less-industrialized countries. Hence, the labor standards issues relevant to the WTO will be those associated with import-competing industries.

previously, in the absence of the ability to negotiate an agreement over labor standards, it will be efficient for the trade agreement to call for partial liberalization of the domestic import tariff to  $\tau^G$  with the domestic labor standard then set unilaterally by the domestic government at a level  $s^G$  that lies below the efficient level  $s^E$ . When labor standards are added to the negotiating agenda, it is then possible to implement an agreement on tariffs and labor standards that achieves the efficient outcome of free trade and a domestic labor standard set to  $s^E$ , as the bottom panel of Figure 7 indicates. But this implies that the addition of labor standards to the international negotiating agenda provides new impetus for further tariff liberalization, as the reason for failing to negotiate to free trade in the first place has been removed. Hence, the addition of labor standards to the international negotiating agenda will bring about negotiations which both tighten labor standards and lead to further reductions in tariffs.

While the introduction of direct negotiations over labor standards can address the inefficiencies associated with negotiations over tariffs alone, this approach nevertheless requires that governments completely relinquish their national sovereignty over labor standards, a policy issue that has traditionally been considered a “domestic” concern. In fact, as we have shown above, it is the sovereign control over labor standards and the implied right to set these standards unilaterally that causes the problem. But are there approaches to negotiation that can achieve efficient outcomes and yet allow governments to preserve some degree of sovereignty over the determination of their labor standards? As it turns out, the answer is “yes,” and in the remainder of this section we describe two additional approaches to negotiation that will achieve efficient outcomes but that do not require direct negotiations over labor standards.

To understand how it is possible to provide the domestic government with some degree of unilateral control over its labor standards and yet achieve a fully efficient outcome through direct negotiations over tariffs alone, it is helpful to consider more closely the unilateral incentives that the domestic government would have to distort its labor policy choice starting from the fully efficient agreement. The bottom panel of Figure 7, which characterizes the determination of the fully efficient agreement, can help to reveal these incentives. Recall that this agreement eliminates the domestic

import tariff and sets the domestic labor standard at  $s^E$ , where the gain in domestic surplus created by a slight reduction in  $s$  would just be offset by the associated loss in domestic *and foreign* gains from trade. Of course, from a unilateral perspective, the domestic government will not value the gains from trade that its labor policies create for its trading partner, and it is because of this that the domestic government has a unilateral incentive to weaken its labor policy from  $s^E$ . But this suggests that if the domestic government were granted the freedom to make unilateral adjustments to its labor policy, it would face the “right” incentives to make efficient choices *provided that it was obligated to make offsetting adjustments to its tariff which preserved the gains from trade of the foreign country*. The gains from trade for the foreign country are determined in turn by the foreign price of  $x$ , and so this obligation would amount to a commitment by the domestic government to make offsetting tariff changes which *preserve the foreign export price* as it adjusts its labor standards. This basic logic underlies the final two approaches to negotiations that we now describe.

The first of these alternative negotiation approaches bears a strong resemblance to the findings of Kemp and Wan (1976), who showed that the membership of a customs union could always be increased in such a way as to raise the national income of member-countries without reducing the national income of any non-member country, by adjusting the (common) external tariff of the customs union to preserve export prices. In the present setting, we suppose that the two governments negotiate an agreed level of tariffs, and then that the domestic government is free to unilaterally alter its labor standard provided that it simultaneously makes *Kemp-Wan adjustments* to its import tariff which preserve the foreign export price at the level implied by the negotiated tariff (and the domestic labor standard in place at the time of tariff negotiations).

Figure 8 illustrates. We suppose that the two countries have previously engaged in negotiations over tariffs alone (with unrestricted sovereignty granted to the domestic government over its labor standard), so that they begin from the (constrained) efficient tariff and labor policies first characterized in Figure 6. We then suppose that, in the current round of tariff negotiations, it is agreed that if the domestic government subsequently loosens its labor standard from its existing level it will then be obligated to reduce its tariff to offset the impact of its altered labor standards on

the price received by foreign exporters. Conversely, if the domestic government subsequently tightens its labor standard from its existing level, then it is agreed that it will be able to raise its tariff to offset the impact of its altered labor standards on the price received by foreign exporters. As these Kemp-Wan tariff adjustments eliminate the ability of the domestic government to use subsequent alterations of its labor standards to capture a portion of the foreign country's gains from trade under the tariff agreement, they will ensure that the domestic government has the "right" incentives when selecting its labor standard, given any negotiated foreign export price (and foreign gains from trade) that it must preserve. The only task of the current round of tariff negotiations is then to ensure that the domestic government faces the "right" (i.e. efficient) foreign export price when making its unilateral labor standard decisions.

In the top panel of Figure 8, the efficient foreign export price is labeled  $p_x^{E*}$ , and is determined by the free trade equilibrium in which the domestic labor standard is set at its efficient level  $s^E$ . Since the domestic labor standard  $s^G$  in place at the time of (the current) tariff negotiations is below  $s^E$ , efficient tariff negotiations that result in a foreign export price of  $p_x^{E*}$  will require the liberalization of the domestic tariff from its initial level of  $\tau^G$  to a level that is initially below the efficient tariff of zero (i.e., an import subsidy). This is depicted in the top panel of Figure 8, and notice that a new dead weight loss triangle labeled  $D'$  has been created by the tariff agreement given the existing domestic labor standard. Hence, neither the tariff nor the domestic labor standard is efficient at this point.

Following the conclusion of the round of tariff negotiations, the domestic government will then be free to unilaterally adjust its labor standard while making Kemp-Wan adjustments to its import tariff. The bottom panel of Figure 8 depicts these adjustments. As the obligation to make Kemp-Wan adjustments will prevent the domestic government from capturing a portion of the foreign gains from the tariff agreement by weakening its labor standard, it will have no incentive to do so. On the other hand, as Kemp-Wan adjustments permit the domestic government to raise its tariff as it raises its labor standard, they allow the domestic government to capture *all* the additional gains from trade created by tighter labor standards. But this implies that the domestic government will

then choose to raise its labor standard to the efficient level  $s^E$  (which, it should be recalled, balanced all the additional gains from trade created by tighter labor standards against the reduction in domestic surplus) and simultaneously raise its import tariff to free trade (from an initial import subsidy). At these (efficient) policy choices, the domestic government can do no better for itself, as it is committed through Kemp-Wan adjustments to the efficient foreign export price and therefore to preserving foreign surplus at its efficient level.<sup>14</sup> Hence, *international negotiations over tariffs alone with Kemp-Wan adjustments will achieve efficient trade and labor policies.*

In Figure 9 we summarize the relationships derived above and depict the logic of Kemp-Wan adjustments from a slightly different perspective. In this figure we plot the domestic import tariff  $\tau$  on the horizontal axis and the domestic labor standard  $s$  on the vertical axis. The efficient policy combination of free trade and a domestic labor standard set at  $s^E$  is labeled as point  $E$  in the figure, and this represents the goal of international negotiations. Also depicted running through point  $E$  is a “Kemp-Wan” curve (labeled  $p_x^{E*}$ ) that reflects combinations of  $\tau$  and  $s$  that fix the foreign export price at  $p_x^{E*}$ . The curve labeled  $s(\tau)$  depicts the domestic country’s preferred choice of labor standard  $s$  for any level of import protection  $\tau$ , and it describes a constraint by which international negotiations over tariffs alone must abide as long as the domestic government is granted unrestricted sovereignty over its labor standard. At every point along this curve, the domestic country’s indifference curves (labeled  $W$ ) are vertical. The point on this curve labeled  $G$  depicts the (constrained) efficient tariff and labor policies  $\tau^G$  and  $s^G$ , where world surplus is maximized subject to the constraint given by  $s(\tau)$ : this is reflected in the figure by the tangency at point  $G$  between the constraint  $s(\tau)$  and the iso-world-surplus curve labeled  $W+W^*$ . It is from point  $G$  that the new “Kemp-Wan” round of tariff negotiations begins. The two-step procedure to move from  $G$  to  $E$

---

<sup>14</sup>Above we have outlined a two-step process that achieves efficient trade and labor policies, under which the domestic government first reduces its tariff in the context of a tariff negotiation with the foreign government and then subsequently raises its tariff and labor standard in a Kemp-Wan fashion. As our discussion indicates, domestic welfare rises throughout the second step of this process while foreign welfare remains unchanged. To ensure that each country gains as well in the first (negotiation) step, it will be necessary for the foreign government to make an international lump-sum transfer to the domestic government in exchange for its tariff cut. The assumption that such transfers are feasible simplifies our analysis, but it is not required for our results (see Bagwell and Staiger, 1998).

described above can now be readily seen in Figure 9. With the labor standard  $s^G$  taken as given in the first step, tariff negotiations reduce the import tariff  $\tau$  along the horizontal line through  $G$  until the “Kemp-Wan” curve  $p_x^{E^*}$  is hit (at point  $B$  in the figure). Then in the second step, the domestic country is granted limited sovereignty to make any Kemp-Wan adjustments to its policy mix that it desires (i.e., it must remain on the curve  $p_x^{E^*}$ ). But as Figure 9 makes clear, the Kemp-Wan adjustments made by the domestic country will lead the world to the efficient point  $E$ , as the policy combination associated with point  $E$  provides the domestic country with the highest level of welfare it can achieve along the “Kemp-Wan” curve (as reflected in the tangency between  $p_x^{E^*}$  and the domestic country’s indifference curve at point  $E$ ). In this way, efficiency can be achieved without international negotiations over domestic labor standards.

While we have shown that direct negotiations over labor standards are not required to achieve efficient outcomes, it is nevertheless important to observe that the loss of domestic sovereignty implicit in the second negotiating approach we have outlined above is substantial, especially when compared to current norms under the GATT/WTO. In particular, the combination of tariff negotiations and Kemp-Wan adjustments as we have described them above require that governments are to be held rigidly to the export prices and trade volumes implied (in light of initial labor standards) by the outcome of their tariff negotiations. By contrast, under current GATT practice the trade volumes implied by a negotiated tariff agreement are not considered rigid commitments. In particular, GATT rules (and more specifically GATT’s Article XXVIII) reserve for member-governments the right to unilaterally raise tariffs above previously-agreed-to levels. When a government exercises this right and denies previously negotiated “market access” to its trading partners, its trading partners are then allowed under GATT rules to take *reciprocal* actions which deny it an equivalent degree of access to their markets. As we have emphasized elsewhere (see, for example, Bagwell and Staiger, 1996, 1997, forthcoming), these reciprocal actions will serve to stabilize the export-price effects of a government’s initial decision to unilaterally raise its tariffs above previously-agreed-to levels. Hence, under current GATT practice, governments *are* effectively held to the export prices implied by their tariff negotiations. But they are *not* held to the implied trade volumes.

Thus, while the second negotiating approach we have described above would imply that governments must commit to both the export prices and the trade volumes that emerge from a tariff negotiation, GATT's existing emphasis on reciprocity implies that governments are effectively only committing to the export prices that emerge from tariff negotiations. We now ask whether these more limited tariff commitments might be combined with subsequent Kemp-Wan adjustments to again allow governments to reach efficient outcomes through tariff negotiations alone. In particular, in a third and final approach to negotiations we suppose that the two governments negotiate an agreed level of tariffs, and that subsequent to tariff negotiations (i) either government is free to announce that it plans to raise its tariff, at which point its trading partner will then be free to increase its tariff by a reciprocal amount, and (ii) the domestic government is free to alter its labor standard provided that it simultaneously makes Kemp-Wan adjustments to its tariff.

To evaluate this final negotiating approach, we must introduce a second good,  $y$ , imported by the foreign country and subject to a foreign import tariff. As this good serves effectively only to provide the foreign government with a means to take "reciprocal" tariff actions in response to the actions of the domestic government, we keep this industry as simple as possible and abstract from issues of labor standards in industry  $y$  either at home or abroad. Instead, we assume simply that, with  $p_y$  denoting the domestic market price of good  $y$ , domestic demand for good  $y$  is given by  $C_y = 1 - p_y$  while domestic supply is given by  $Q_y = 1 + p_y$ . Similarly, with  $p_y^*$  denoting the foreign market price of good  $y$ , we assume that foreign demand and supply of good  $y$  are given, respectively, by  $C_y^* = 1 - p_y^*$  and  $Q_y^* = p_y^*$ . Finally, foreign import demand for good  $y$  is then defined by  $M_y^*(p_y^*) \equiv C_y^*(p_y^*) - Q_y^*(p_y^*)$ , while domestic export supply of good  $y$  is defined by  $E_y(p_y) \equiv Q_y(p_y) - C_y(p_y)$ .

Our final task before considering this third approach to negotiations is to define what is meant by *reciprocity* in a tariff agreement. Here we follow our earlier work (see, for example, Bagwell and Staiger, 1997, forthcoming) and assume under the tariff agreement that, if subsequent to implementing the agreement the domestic government wishes to raise its tariff so as to reduce foreign export volume into its markets, then it will be free to do so. However, in this event, the foreign

government will be permitted to raise its tariff *reciprocally* so as to reduce by the same amount the domestic export volume into its markets. Of course, the foreign government enjoys a symmetric right to initiate modification of its own tariff and can expect under the tariff agreement a reciprocal response from the domestic government. It can be shown that, in the present context, the implied tariff modifications to any original agreement under reciprocity must satisfy

$$[p_x^{*o} - p_x^{*m}]M_x^m = [p_y^o - p_y^m]M_y^{*m},$$

where the superscript “o” denotes magnitudes implied under the original tariff agreement and the superscript “m” denotes magnitudes associated with the modified tariff agreement. Effectively, this restriction ensures that the export price effects of one government’s decision to raise its tariff will be neutralized by the export price effects of the tariff increase permitted under the rule of reciprocity by its trading partner. In our earlier work we assumed that government policies consisted solely of tariffs, and showed that reciprocity as described above could guide governments to efficient tariff agreements. In the present context government policies also include the domestic labor standard, and we now show that, *when combined with subsequent Kemp-Wan adjustments, reciprocity will guide governments through international negotiations over tariffs alone to achieve efficient tariff and labor policies.*

Having described the restrictions on modifications to an original tariff agreement that are allowed under reciprocity, we may now characterize the tariff agreement that will be negotiated under reciprocity with subsequent Kemp-Wan adjustments. Figure 10 illustrates. For simplicity, we suppose as before that the two countries have previously engaged in negotiations over tariffs alone (without reciprocity and with unrestricted sovereignty granted to the domestic government over its labor standard). This implies that as the current round of negotiations begins, the two governments will begin from free trade in good y (recall that we have for simplicity assumed away any labor standard issues in industry y), and they will begin from the (constrained) efficient tariff and labor policies characterized in Figure 6 for good x. Now suppose that, as depicted in the top panel of Figure 10, the two governments were to negotiate the same degree of tariff liberalization in industry

x as they would have negotiated (in the absence of reciprocity) under the Kemp-Wan adjustments of Figure 8. It can now be seen from the bottom panel of Figure 10 that the more-limited tariff commitment implied by reciprocity will still allow this outcome to be sustained.

To see this, observe that the third negotiating approach described above will permit the domestic government to make unilateral Kemp-Wan adjustments to its tariff and labor policies in industry x without fear of triggering a tariff response from the foreign government, as these adjustments preserve the foreign export price  $p_x^*$  and thus do not invite the foreign government to alter its tariff under reciprocity (i.e., so as to induce reciprocal changes in the domestic export price  $p_y$ ). As we showed previously, these adjustments will achieve the efficient policy mix in the x industry, with free trade then prevailing in both industries x and y and the efficient domestic labor standard  $s^E$  in place, as the bottom panel of Figure 10 indicates. Furthermore, while either country would still be free under reciprocity to raise its tariff, the reciprocal tariff increase that can be imposed by its trading partner under reciprocity as described above is sufficient to eliminate each government's incentive to close its own import markets. Hence, when combined with subsequent Kemp-Wan adjustments, reciprocity will guide governments through international negotiations over tariffs alone to achieve efficient tariff and labor policies.

Gathering the results of this section together, we have:

**Observation 3:** Any of the following three approaches to multilateral trade negotiations could allow governments to reach a globally efficient outcome achieved by complete tariff liberalization and a strengthening of labor standards:

- (A) Introduce the issue of labor standards directly on to the agenda of multilateral trade negotiations and negotiate commitments over both tariffs and labor standards;
- (B) Exclude the issue of labor standards from multilateral negotiations and negotiate commitments over tariffs alone, but subsequent to tariff

negotiations allow any country wishing to strengthen its labor standards to increase its tariff levels as well, provided that its tariff adjustments are made to neutralize the export-price effects of its strengthened labor standards; or

- (C) Exclude the issue of labor standards from multilateral negotiations and negotiate commitments over tariffs alone, but subsequent to tariff negotiations (i) allow any country to raise its tariffs, provided that its trading partners have the right to reciprocate with tariff increases of their own which serve to stabilize export prices, and (ii) allow any country wishing to strengthen its labor standards to increase its tariff levels as well, provided that its tariff adjustments are made to neutralize the export-price effects of its strengthened labor standards.

It is interesting to observe that, from the perspective of the GATT/WTO, approach (C) effectively amounts to permitting countries to credit changes in their labor standards as a “compensatory adjustment” when engaged in Article XXVIII tariff renegotiations. Consequently, our results suggest that relatively straightforward changes to the rules of GATT could allow governments to implement efficient labor standards without the need for direct international negotiations over these policies.

Finally, we note that there is an important distinction between these changes to the rules of GATT and the changes that have been proposed in recent WTO discussions, namely, the formal inclusion of a “social clause” that would permit restrictions to be placed on imports from countries not complying with a specified list of minimum standards. These proposed changes would allow governments to raise import restrictions in response to the weak labor standards of their trading partners, possibly by expanding GATT’s Article XX (which currently permits tariffs to be raised against the importation of the products of prison labor) or Article VI (under which countervailing duties can be imposed against imports that are subsidized). In contrast, the changes suggested by our analysis would instead allow governments to raise import restrictions in exchange for tightening their

own labor standards. This reorientation linking the permissible level of import protection in GATT to one's *own* labor standards rather than the labor standards of one's trading partners is a fundamental feature of our analysis, and this feature is likely to appear in settings which are much more general than the simple model we have used here to illustrate it.

## VI. Conclusion

How should the issue of domestic labor standards be handled in the GATT/WTO? This is a question that is currently before the WTO, where member-countries are considering proposals for a new round of negotiations that would move beyond GATT's existing focus on trade barriers and cover "domestic" issues such as labor and environmental standards and regulatory reform, issues that have traditionally been treated with "benign neglect" within GATT.

In this paper we have considered several approaches to the treatment of domestic labor standards within a trade agreement. We have used simple economic arguments to show that, while the benign neglect of labor standards within a trade agreement will result in inefficient choices for both trade barriers and labor standards, direct negotiations over labor standards are *not* required to reach efficient outcomes. Specifically, we have described two alternative tariff negotiating structures that deliver efficient outcomes while preserving varying degrees of national sovereignty over policy choices. A first approach combines tariff negotiations with subsequent *Kemp-Wan adjustments*, under which each government is free to alter unilaterally its policy mix so long as trade volumes are not affected. A second approach adds to the first approach GATT's rule of *reciprocity*, under which subsequent to tariff negotiations each government is free to alter unilaterally its tariff, but its trading partner is then free to reciprocate with a tariff response which stabilizes export prices. We have shown that both approaches will deliver governments to the efficiency frontier, but that the second approach provides governments with greater sovereignty over their policy choices and bears a strong resemblance to the negotiating procedures spelled out in GATT.

While in principle our results point toward a relatively simple “fix” for the contentious issue of labor standards in the WTO, in practice there are of course a host of important caveats which must be borne in mind. First among these is the “slippery slope” argument that asks of the WTO, “Why stop at labor standards?” To some degree virtually all domestic policy choices of large economies such as the United States will have implications for export prices in the world economy and hence could be the subject of an analysis similar to that which we have undertaken here. Where, then, should the WTO draw the line? Also important is the question of how, given the complexities of the real world, the trade effects of a given change in domestic labor standards could be assessed with any accuracy.<sup>15</sup> These and other arguments might well be offered up against the advisability of altering the rules of GATT in the way that our formal results suggest. On the other hand, the direct international negotiation of domestic labor standards and the subsequent enforcement of a WTO “social clause” seems itself to be an extraordinarily complex task which is not immune to the “slippery slope” argument, and at the same time this approach crosses a boundary of national sovereignty that has served GATT well for 50 years. Hence, if *anything* is to be done to address the issue of labor standards in the WTO, the new approach that we have highlighted here seems at least worthy of discussion along side the others.

## References

- Bagwell, Kyle and Robert W. Staiger, "An Economic Theory of GATT," **American Economic Review**, forthcoming.
- Bagwell, Kyle and Robert W. Staiger, "Reciprocal Trade Liberalization," NBER Working Paper No. 5488, March 1996.
- Bagwell, Kyle and Robert W. Staiger, "Reciprocity, Non-discrimination and Preferential Agreements in the Multilateral Trading System," NBER Working Paper No. 5932, February 1997.

---

<sup>15</sup>The practicality of Kemp-Wan-type tariff adjustments in the context of customs-union formation has been discussed by McMillan (1993) and Srinivasan (1997).

- Bagwell, Kyle and Robert W. Staiger, "Domestic Policies, National Sovereignty and International Economic Institutions," mimeo, February 1998.
- Bhagwati, Jagdish and Robert E. Hudec (eds.), **Fair Trade and Harmonization: Prerequisites for Free Trade?**, Volume 2 (Legal Analysis), The MIT Press, Cambridge, 1996.
- Brown, Drusilla K., Deardorff, Alan V. and Robert M. Stern, "International Labor Standards and Trade: A Theoretical Analysis," in Bhagwati and Hudec (eds.), **Fair Trade and Harmonization: Prerequisites for Free Trade?**, Volume 1 (Economic Analysis), The MIT Press, Cambridge, 1996.
- Brown, Drusilla K., Deardorff, Alan V. and Robert M. Stern, "Trade and Labor Standards," RSIE Discussion Paper No. 394, March 14, 1997.
- Dam, Kenneth W., **The GATT: Law and International Economic Organization**, Chicago: University of Chicago Press, 1970.
- Enders, Alice, "The Role of the WTO in Minimum Standards," in van Dijck and Faber (eds.), **Challenges to the New World Trade Organization**, Kluwer Law International, The Hague, 1996.
- Jackson, John H., **World Trade and the Law of GATT**, Bobbs-Merrill, New York, 1969.
- Jackson, John H., **The World Trading System**. (The MIT Press, Cambridge: 1989).
- Kemp, Murray C. and Henry Wan, Jr., "An Elementary Proposition Concerning the Formation of Customs Unions," **Journal of International Economics** 6, 1976, pp. 95-98.
- Maskus, Keith, "Should Core Labor Standards be imposed through International Trade Policy?" Policy Research Working Paper No. 1817, The World Bank, August 1997.
- McMillan, John, "Does Regional Integration Foster Open Trade? Economic Theory and GATT's Article XXIV," in Anderson and Blackhurst (eds.), **Regional Integration and the Global Trading System**, St. Martin's Press, New York, 1993.
- Petersmann, Ernst-Ulrich, **The GATT/WTO Dispute Settlement System: International Law, International Organizations and Dispute Settlement**, Kluwer Law International, The Hague, 1997.
- Srinivasan, T.N., "International Trade and Labour Standards from an International Perspective," in van Dijck and Faber (eds.), **Challenges to the New World Trade Organization**, Kluwer Law International, The Hague, 1996.
- Srinivasan, T.N., "The Common External Tariff of a Customs Union: Alternative Approaches," **Japan and the World Economy** 9, 1997, pp. 447-465.

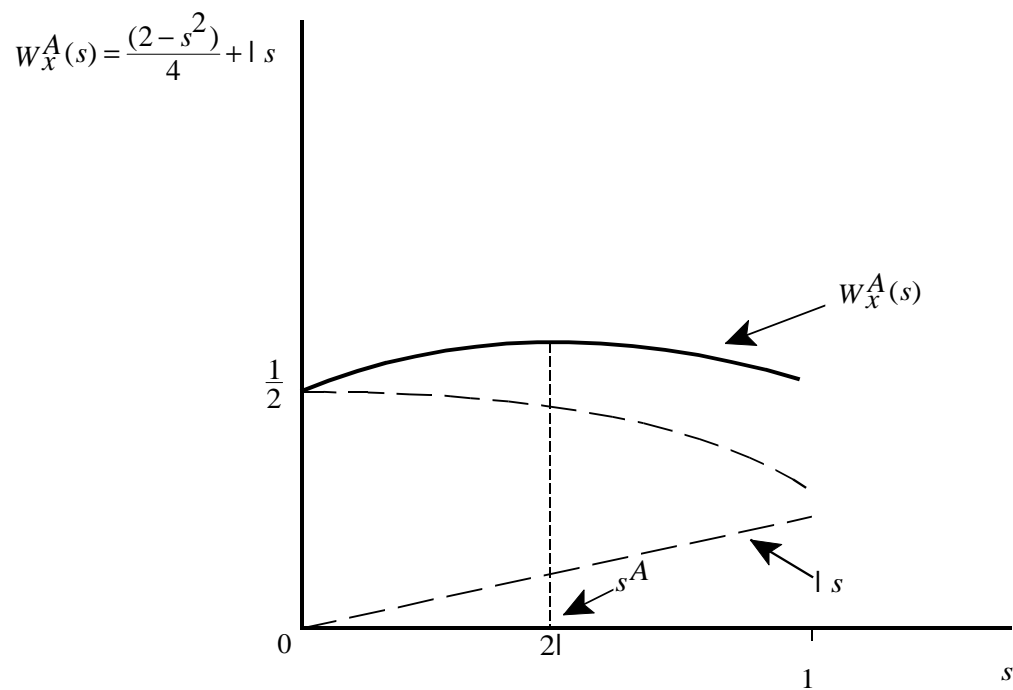
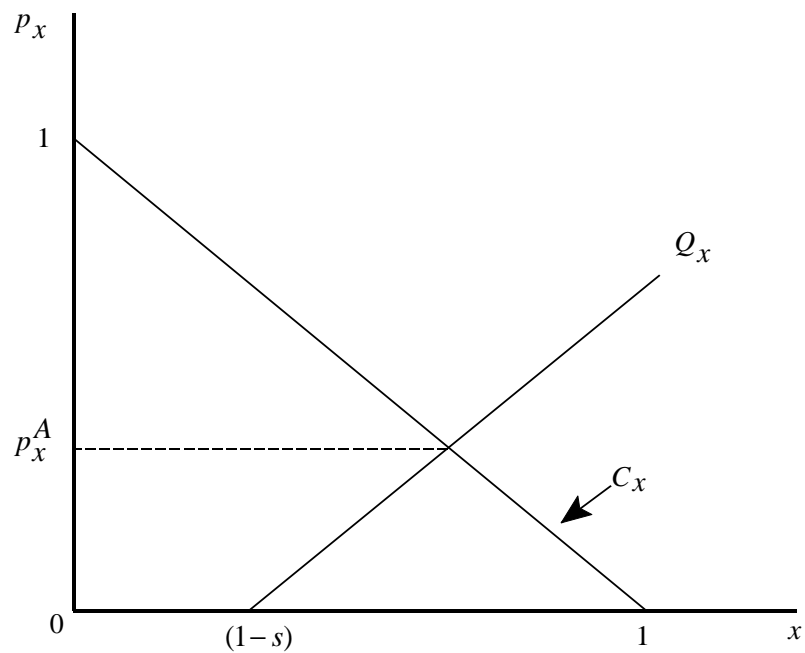

**Figure 1: Determination of Domestic Labor Standards under Autarky**

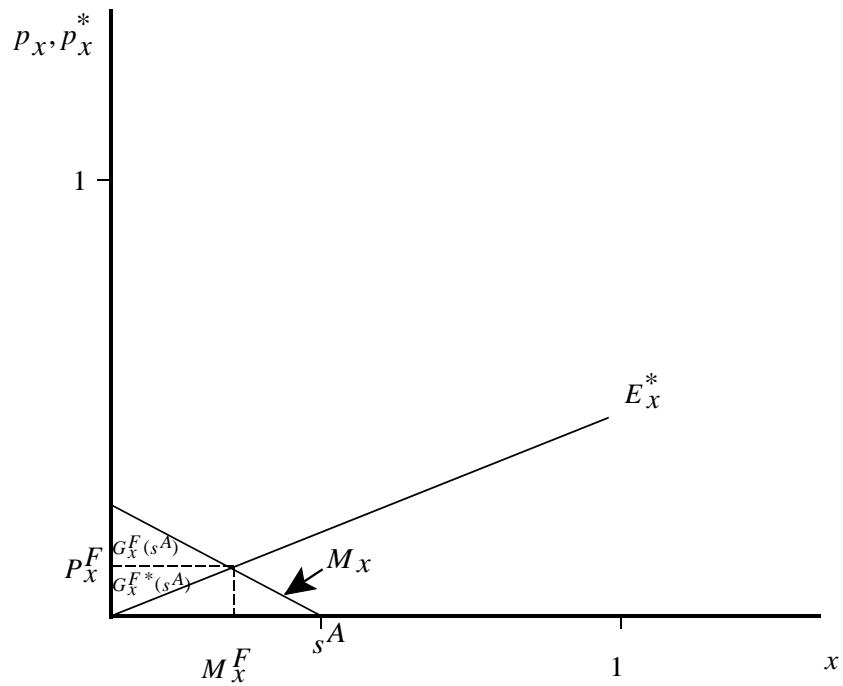
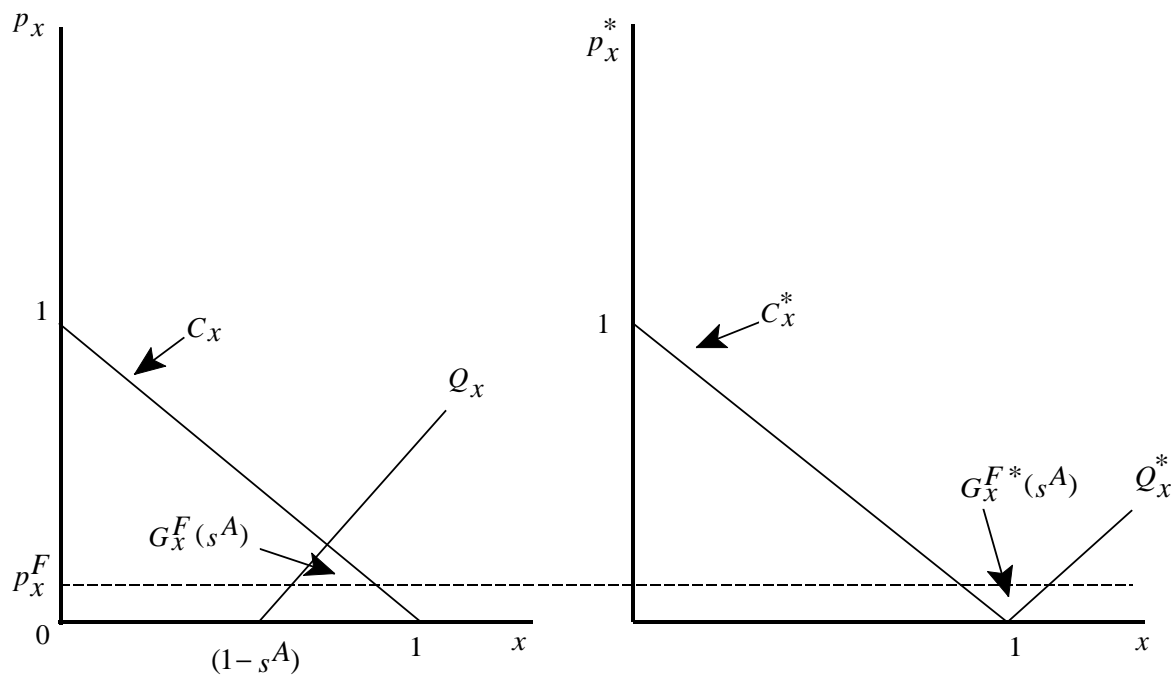

**Figure 2: Introduction of Trade**

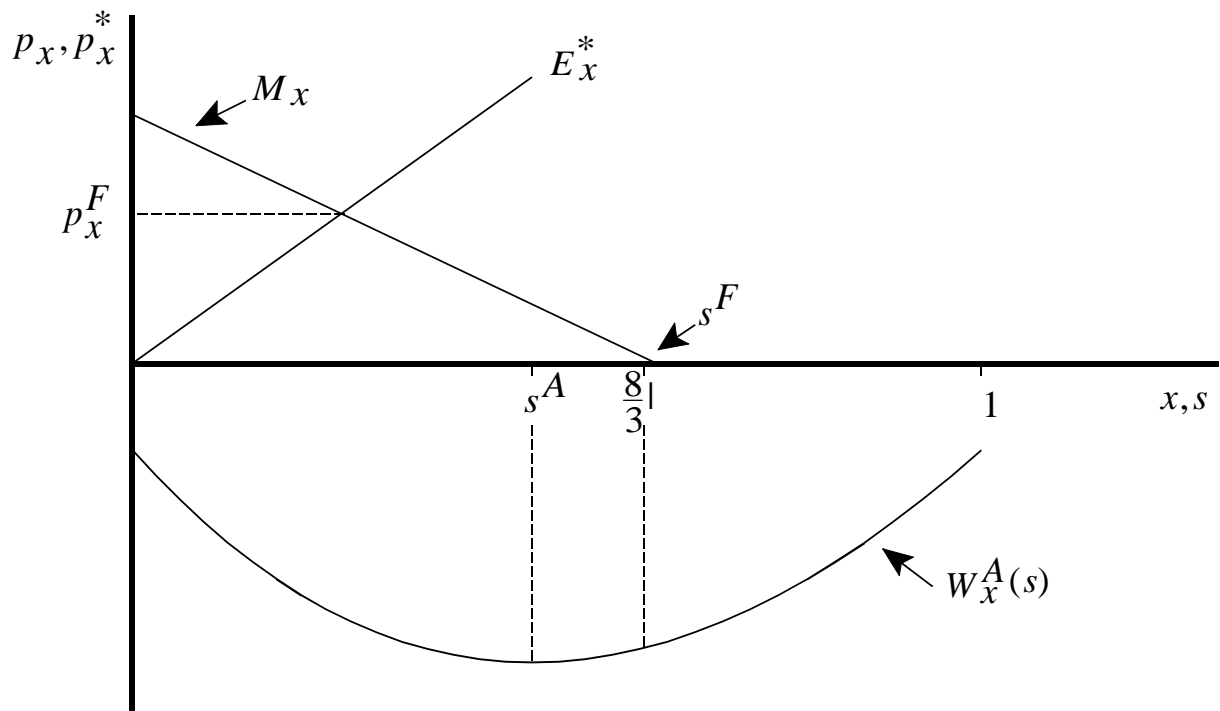
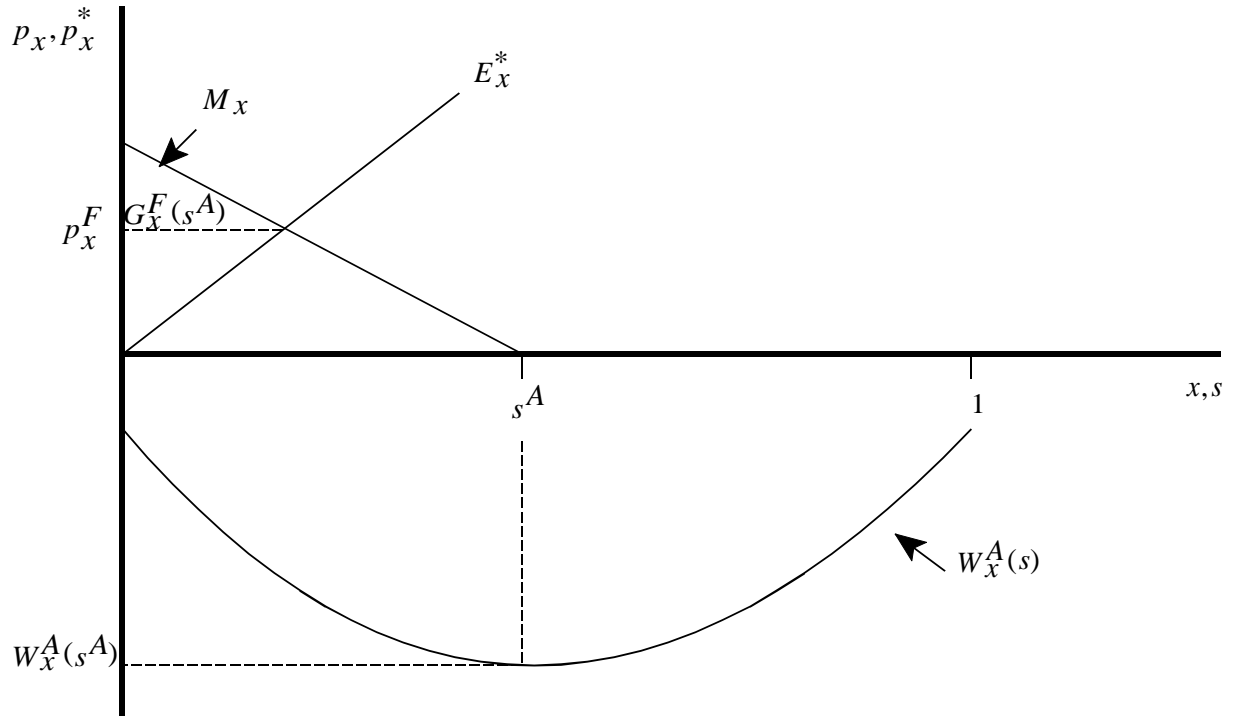
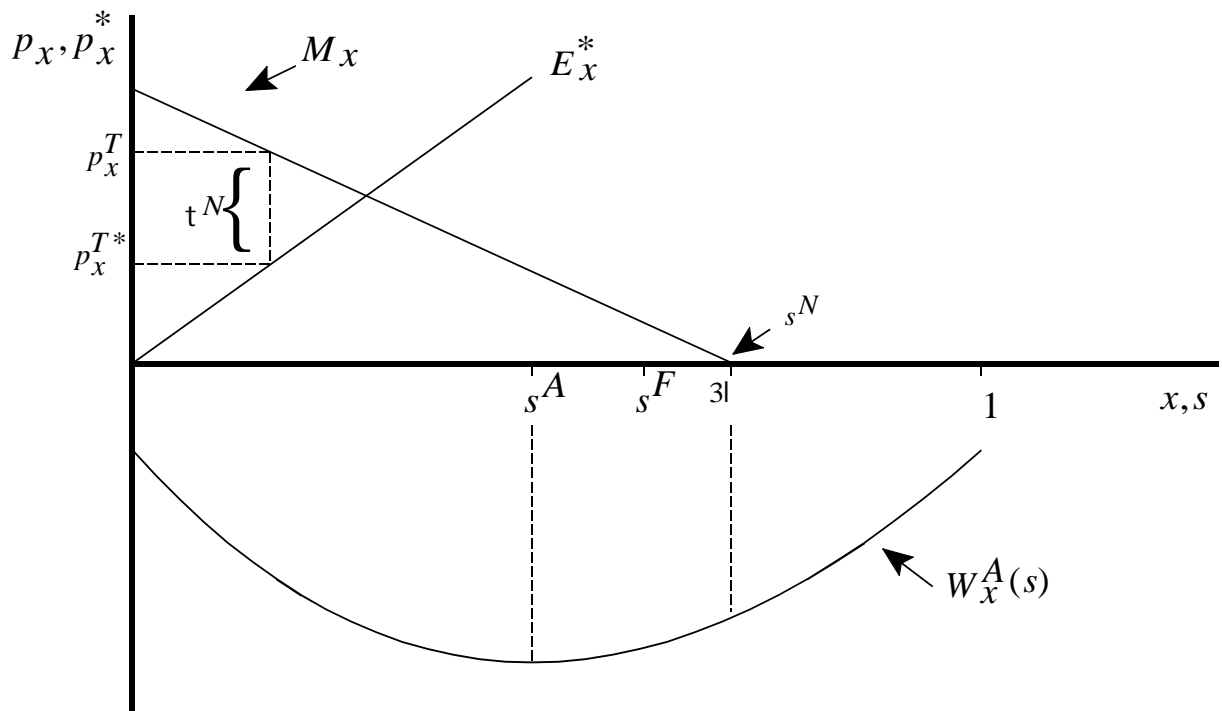
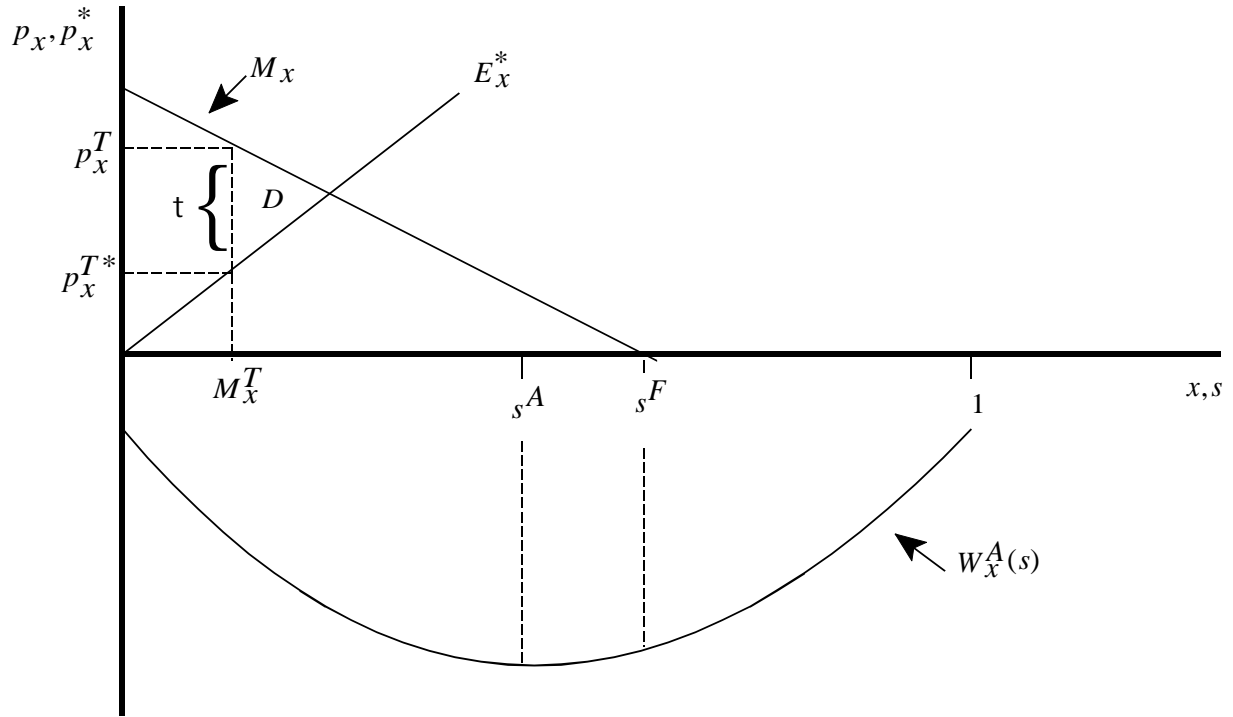
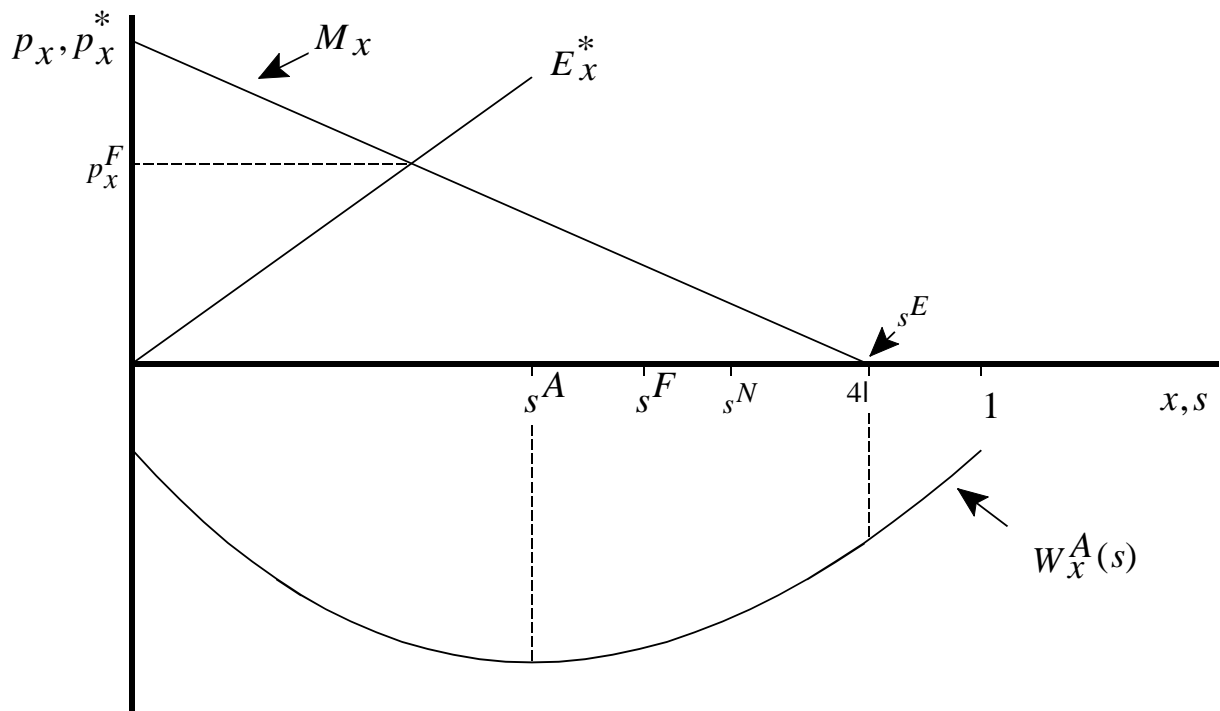
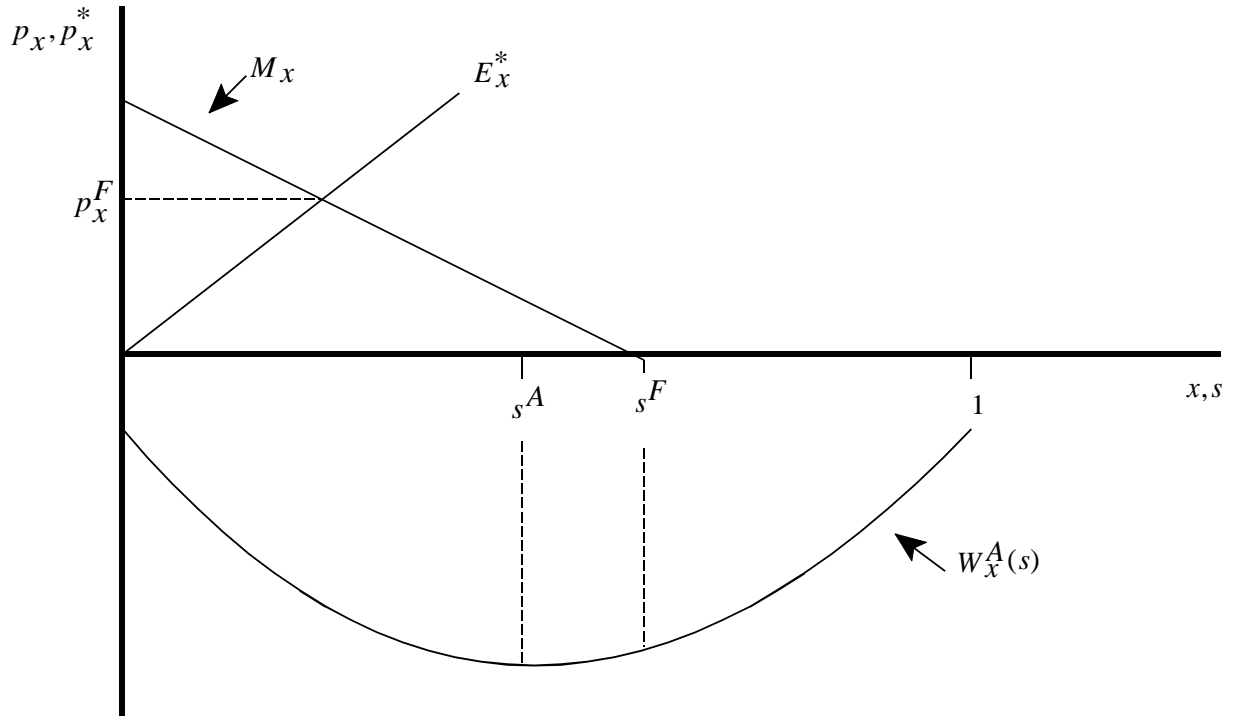

Figure 3: Determination of Domestic Labor Standards under Free Trade



**Figure 4: Determination of Domestic Labor Standards under Non-Cooperative Tariffs**



**Figure 5: Determination of Efficient Tariffs and Labor Standards**

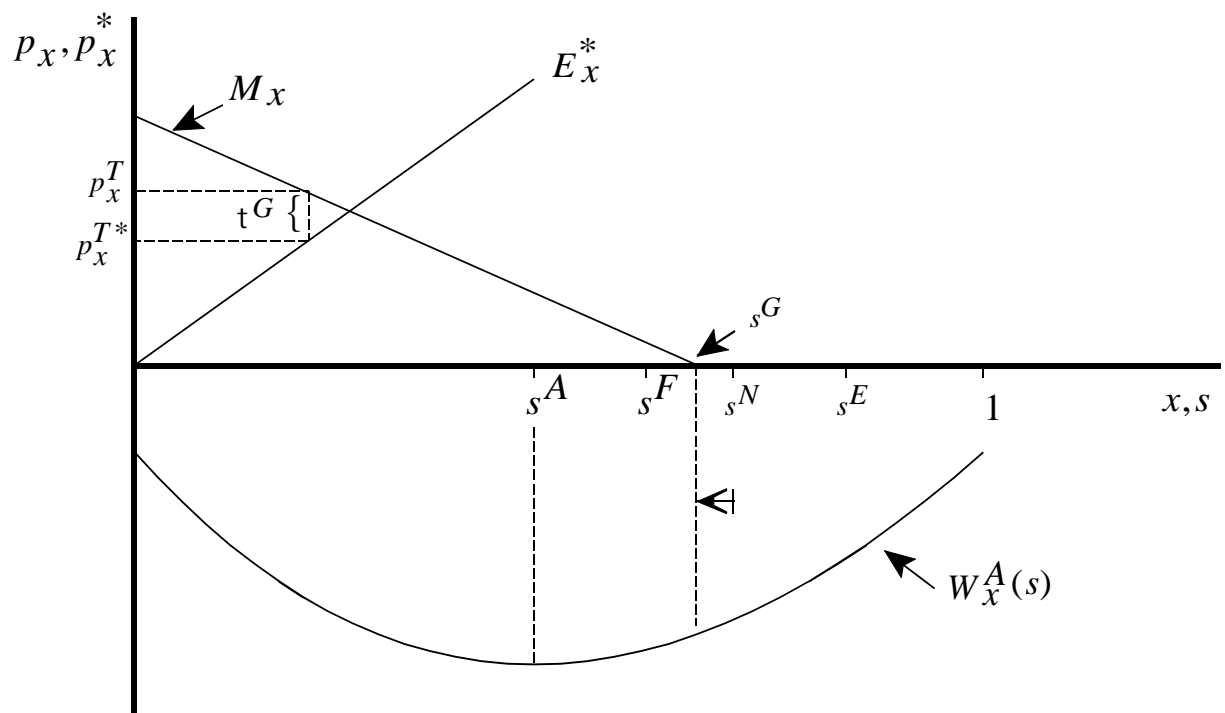
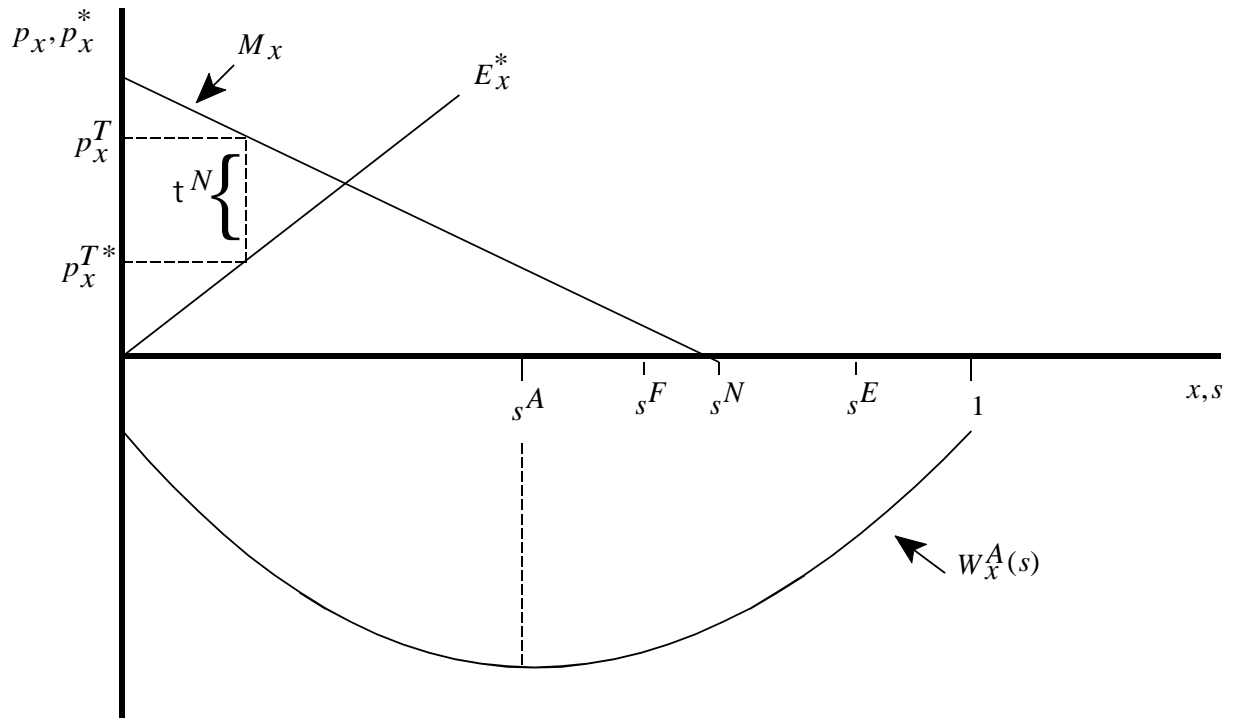
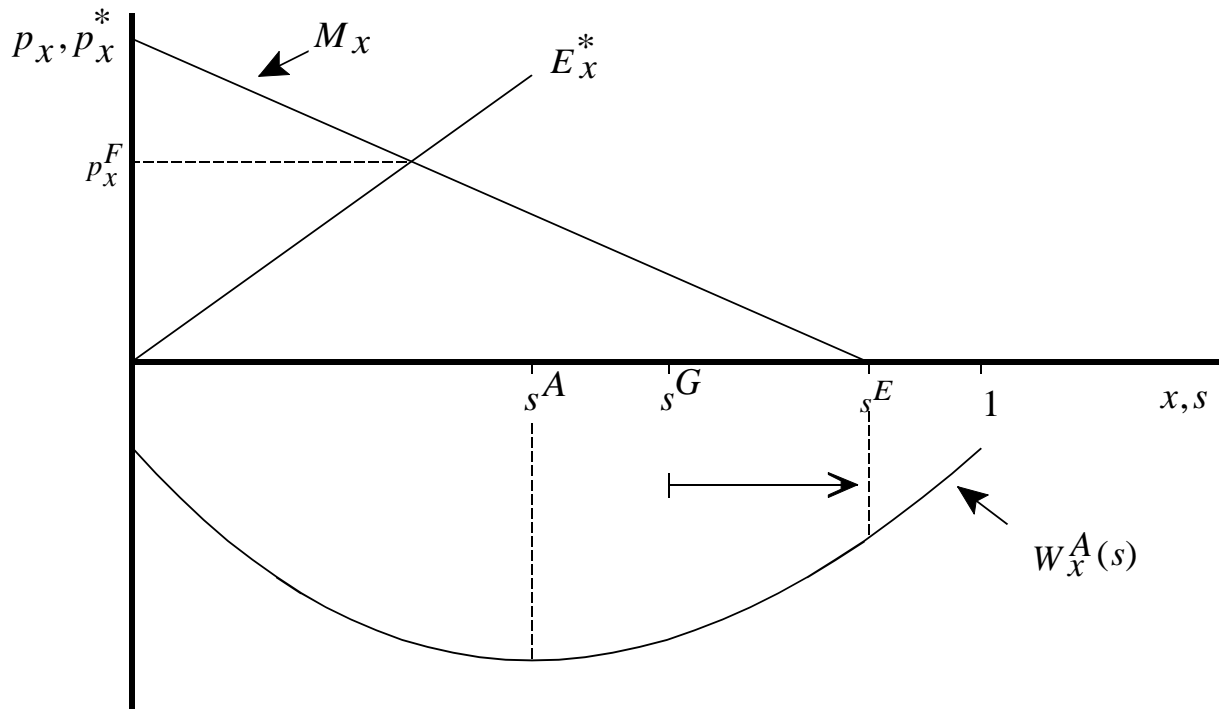
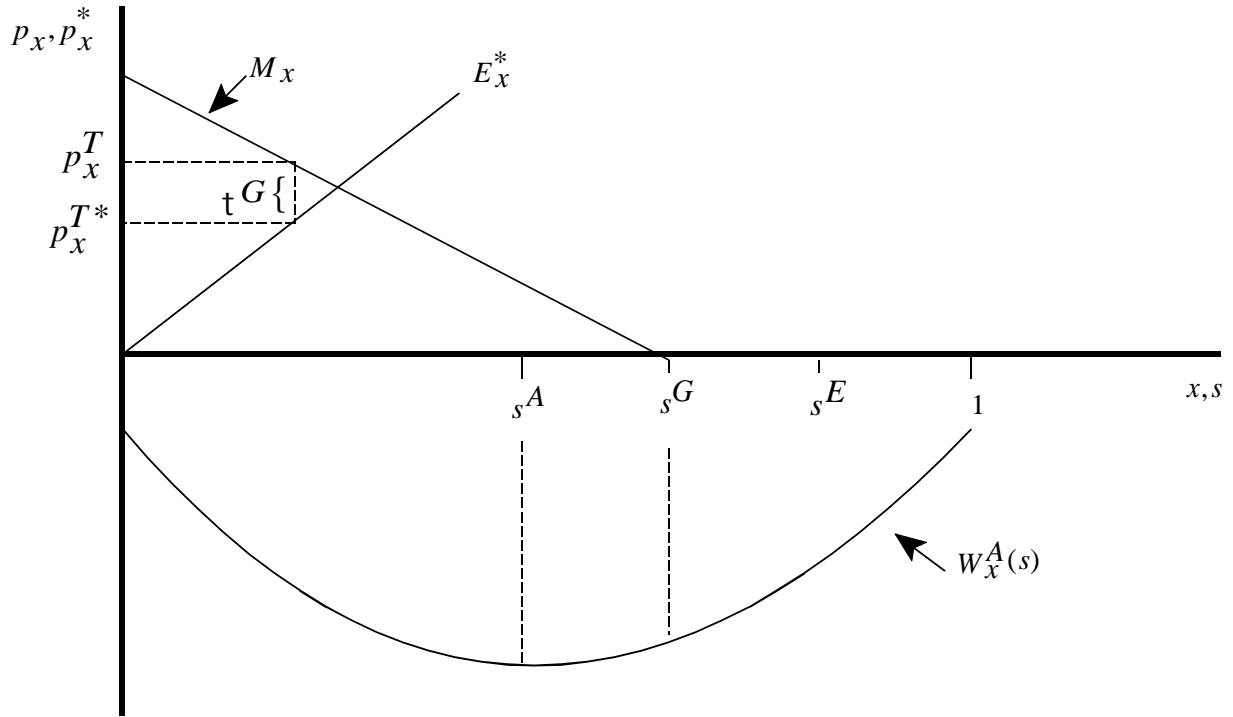
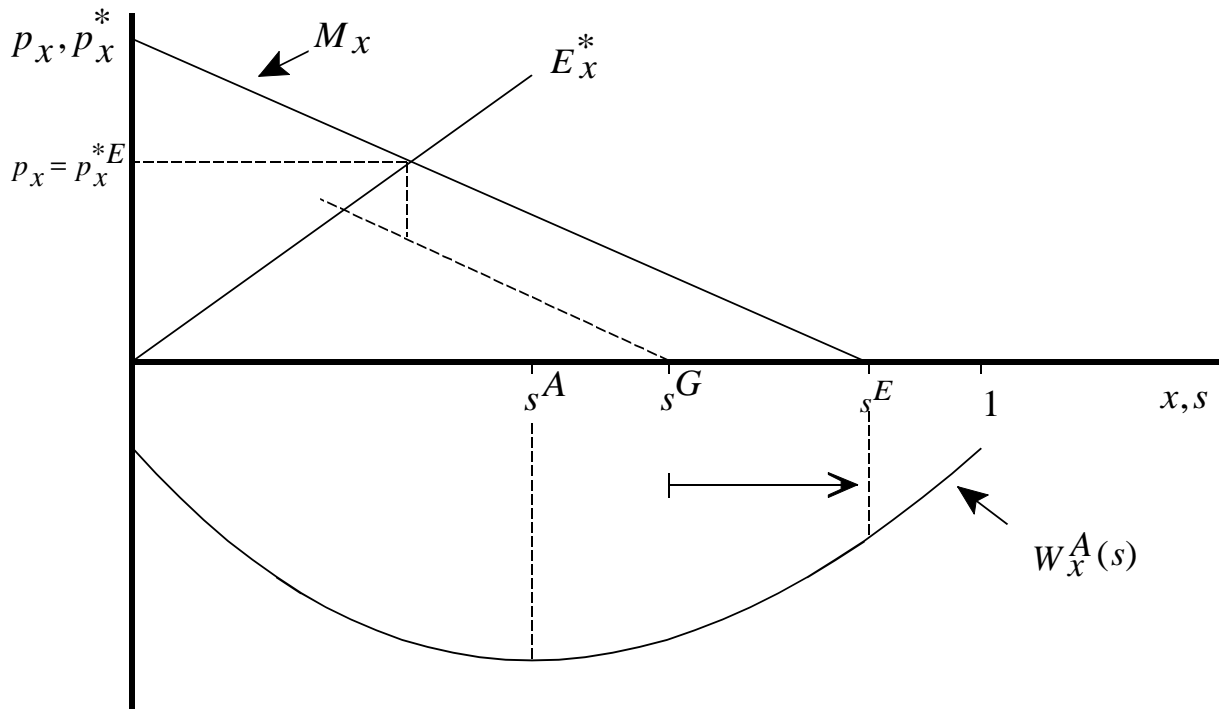
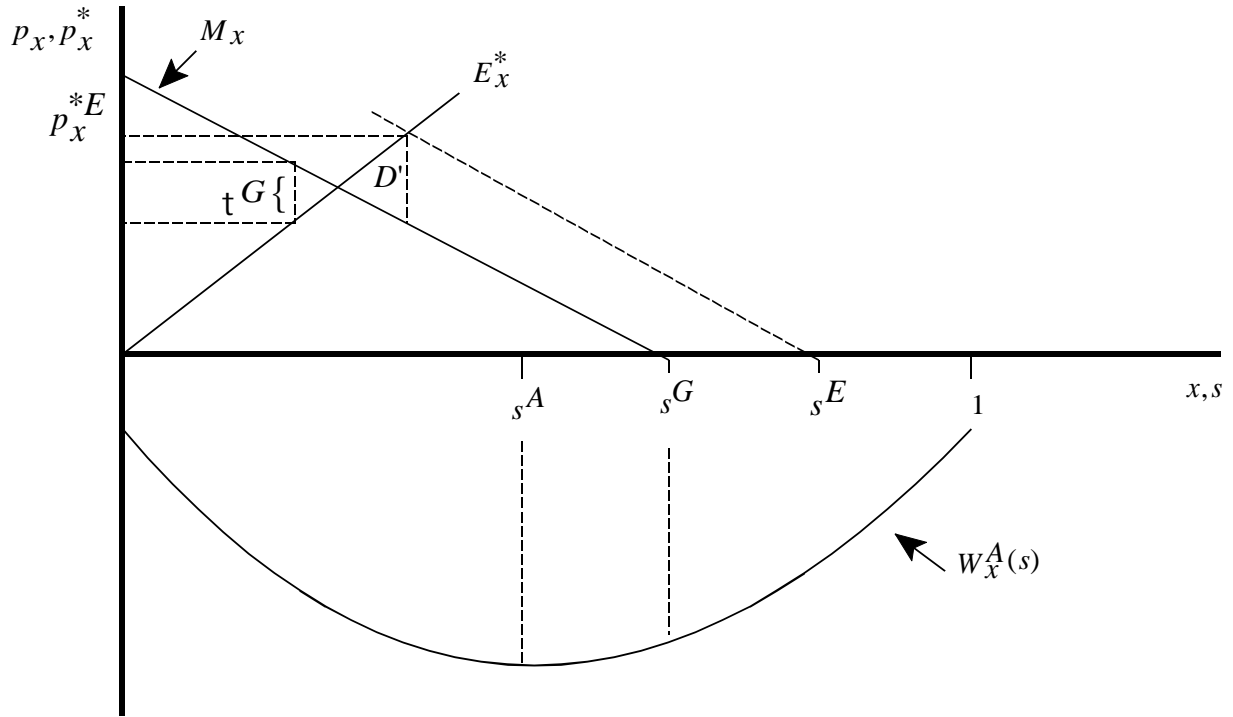

Figure 6: International Negotiations over Tariffs Alone



**Figure 7: International Negotiations over Tariffs and Labor Standards**



**Figure 8: International Negotiations over Tariffs alone with Kemp-Wan Adjustments**

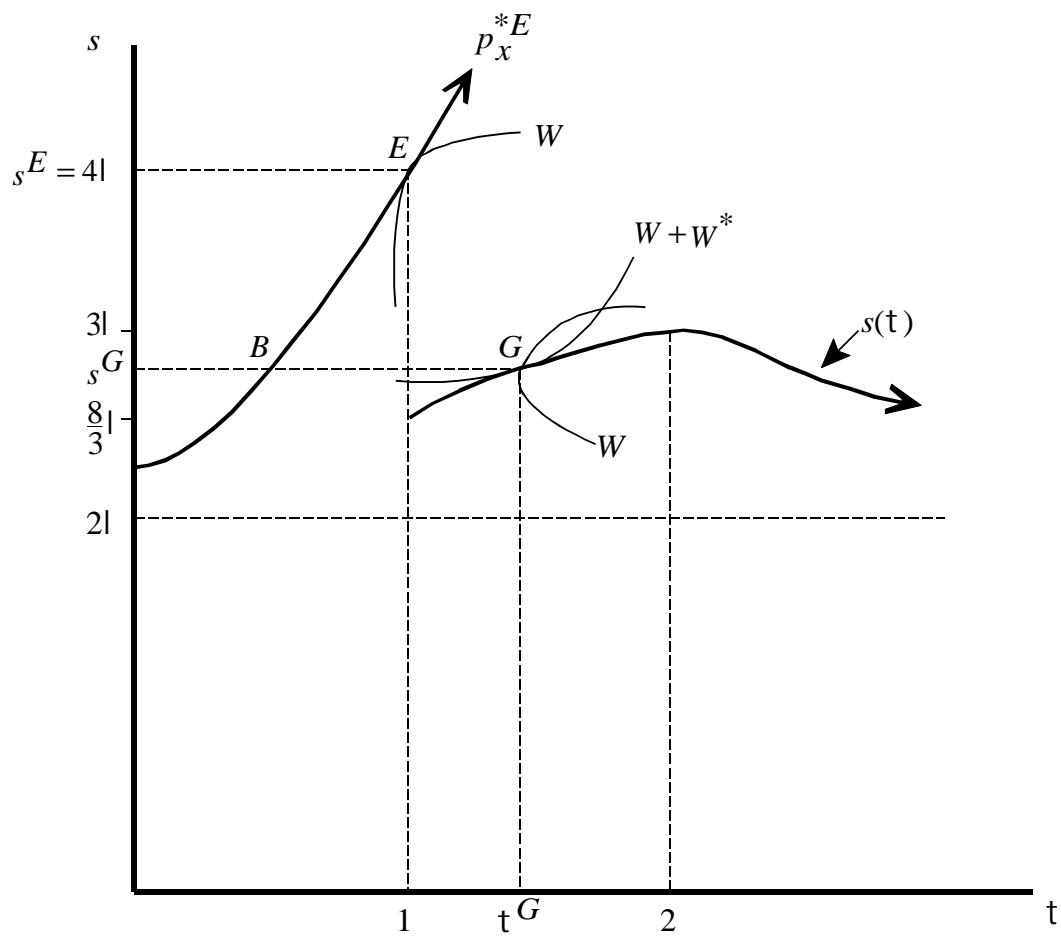

**Figure 9: The Logic of Kemp-Wan Adjustments**

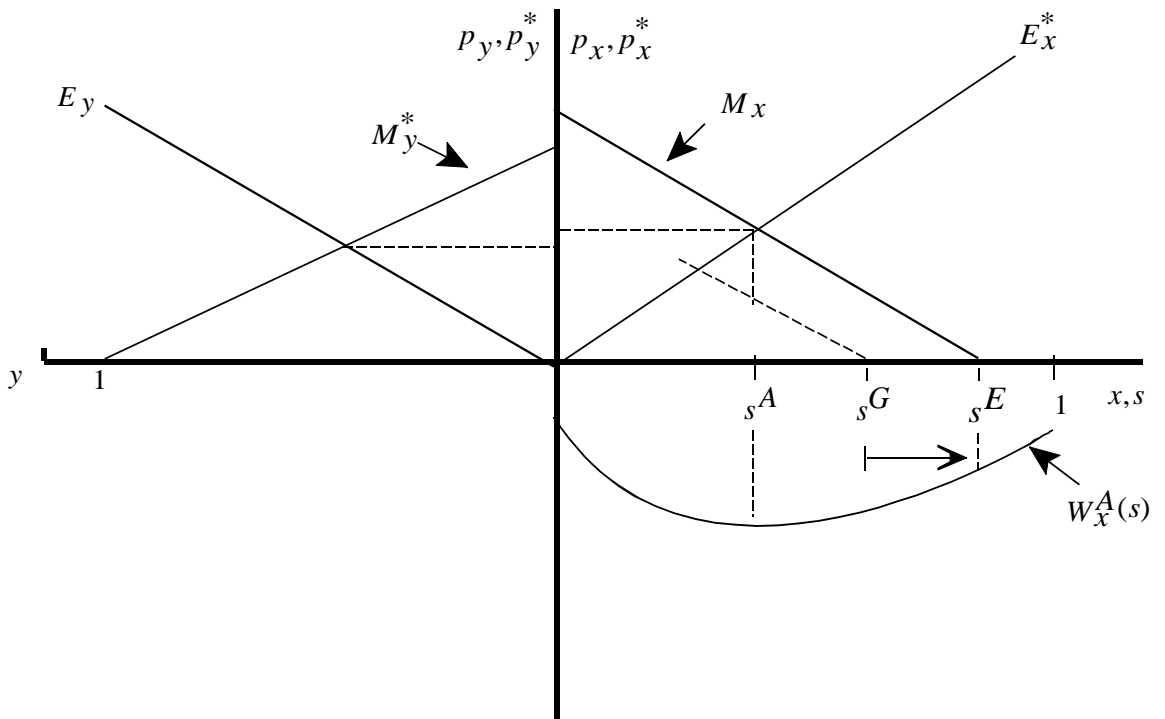
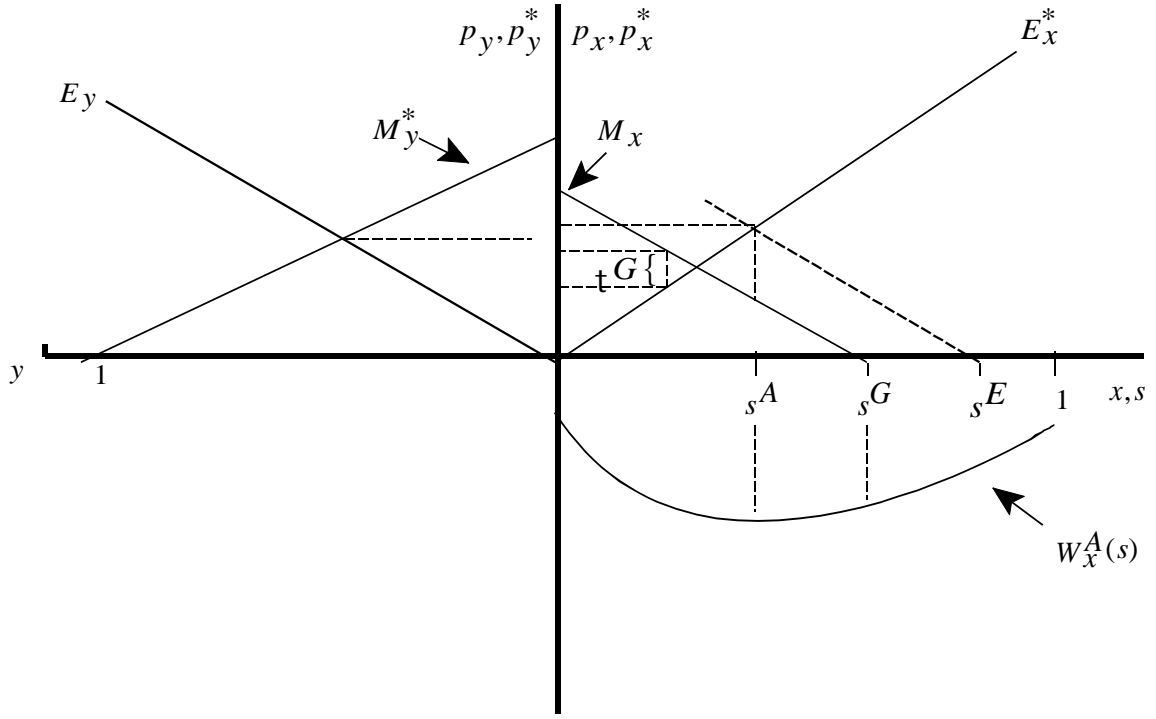

**Figure 10: International Negotiations over Tariffs along with Reciprocity and Kemp-Wan Adjustments**